

**ASSOCIATION OF
AUTHORISING
BODIES**



RULES & REGULATIONS

2025 EDITION

CLASS 1

PUGEOT 106, CITROEN AX & SAXO



"The Association reserve the right to alter/amend the Rule Book as required, and that the Association has the right to review and amend any Class or Construction Rules at the end of each racing year."

**VALID FROM JANUARY 2025
UNTIL FURTHER NOTICE**

ALL PREVIOUS EDITIONS ARE INVALID

NEW REGULATIONS ARE MARKED #

IT IS THE RESPONSIBILITY OF THE DRIVER/CONSTRUCTOR TO ENSURE THAT ALL VEHICLES CONFORM FULLY TO THE REGULATIONS AND RULES CONTAINED WITHIN THIS RULEBOOK

IF THE REGULATIONS AND RULES DO NOT STATE THAT "YOU CAN DO IT" THEN IT MUST BE PRESUMED THAT IT CANNOT BE DONE.

CLASS 1 **PUGEOT 106 & CITROEN AX & SAXO**

**FOR GENERAL BASIC CONSTRUCTION RULES (i.e., Basic requirements for all class of saloon vehicle).
SEE SEPARATE RULE BOOK –SALOONS - GENERAL**

CLASS SPECIFIC CONSTRUCTION RULES

CLASS 1 - PUGUOT 106 & CITROEN AX & SAXO

| INDEX | PAGE |
|------------------------------------|------|
| CLASS SPECIFICATION | 1 |
| VEHICLE CONSTRUCTION RULES GENERAL | 1 |
| 1 Statement of Conformity | 1 |
| 1.1 Engine & Transmission/Gearbox | 1 |
| 2 Chassis/Body Shell | 4 |
| 3 Windscreen Glass | 5 |
| 4 Steering | 5 |
| 5 Safety Harness | 5 |
| 6 Seat | 5 |
| 7 Fire Extinguisher | 6 |
| 8 Identification | 6 |
| 9 Electrical/Instruments | 6 |
| 10 Fuel | 6 |
| 11 Cooling Systems | 6 |
| 12 Brakes | 6 |
| 13 Wheels | 6 |
| 14 Tyres | 7 |
| 15 Exhaust | 7 |
| 16 Safety Shields | 7 |
| 17 Suspension | 7 |
| 18 Protection | 8 |
| 19 Ballast | 8 |
| 20 Vehicle Check Sheets | 8 |
| | |
| DRAWINGS | 11 |
| FIGURES | 12 |

VEHICLE CONSTRUCTION RULES - CLASS 1.**CLASS SPECIFICATION.**

Must be a Front Wheel Drive Saloon of specified type and manufacture.

Specified Vehicles – “Right Hand Drive” and “Manual” versions only.

“Automatic” versions prohibited.

All Light Van, Dual Purpose (Pick Up and Estate) models of vehicles are prohibited.

Specified vehicles.

- i. Citroen AX – 1987 to 1997 - 954cc (TU9) engine AX 10E, 10RE, or Debut 954cc 3 or 5 door bodyshells
Excluding 1124cc, 1360cc and AX GT/AX Forte and GTi, Rally & Homologation model variants.
- ii. Citroen Saxo 954cc (TU9) engine 3 or 5 door bodyshells.
Excluding 1124cc, 1360cc and GT/GTi, Rally & Homologation model variants.
- iii. Peugeot 106 954cc (TU9) engine 3 or 5 door bodyshells.
Excluding 1124cc, 1360cc and Rallye and GT/GTi, Rally & Homologation model variants.

NASA reserves the right to amend the above list of vehicles giving 12 months notice regarding the addition or deletion of vehicles.

VEHICLE CONSTRUCTION RULES - GENERAL**1. STATEMENT of CONFORMITY.**

Only methods of construction and modifications as listed are permitted. Any further modifications, other than those permitted, are prohibited. Any modifications other than those listed within the Vehicle Construction Rules are specifically excluded.

i.e., If the rules do not “say” that a modification is permitted then it is not allowed.

1. 1. ENGINE and TRANSMISSION/GEARBOX

- 1.1a). Standard production original manual transmission engine and gearbox components and certain NASA Scrutineers Committee permitted replacement engine/gearbox components only must be used and be correctly fitted.
 - b). The modification or alteration or interchanging of any unspecified part or component of the specified vehicle manufacturer’s engine & gearbox is prohibited. This includes prohibition of using any standard production parts to alter its working design.
 - c). All engine and gearbox mountings must be retained in their original positions, be of good order and be appropriate to that vehicle. Standard production originals and NASA Scrutineers Committee permitted replacement engine/gearbox/axle “mountings” only must be used. Modification to and or of such mountings prohibited. The conversion of “flexible type” mountings to “solid type” mountings prohibited.
- 1.2 Engine & Bodyshell combinations
- i. Citroen AX 954cc
Any Citroen AX 954cc manual transmission engine & gearbox may be used in any year of Citroen AX 10E, 10RE, or Debut 954cc 3 or 5 door bodyshell. It is not permitted to fit the engine into any AX GT/AX Forte and GTi model variants.
 - ii. Citroen Saxo 954cc (TU9) engine 3 or 5 door bodyshells.
Excluding 1124cc, 1360cc and GT/GTi model variants.
 - iii. Peugeot 106 954cc
Any Peugeot 106 954cc manual transmission engine & gearbox may be used in any year of Peugeot 106 954cc 3 or 5 door bodyshell. It is not permitted to fit the engine into any Peugeot 106 Rallye and GT/ GTi model variants.
- 1.3 Crankshaft Stroke.
The crankshaft stroke must remain as fitted to provide the original engine cubic capacity.
The crankshaft journals may be reground and or polished. The maximum permitted regrind is restricted to that for which standard replacement oversize bearings are readily available.
- 1.4 Engine Block.
“Decking/Skimming/Re-facing” of engine block top surface prohibited.
- Cylinder Bore
The maximum permitted overbore is restricted to that for which standard replacement oversize pistons and/or pistons and liners are available.
The overbore or re-bore is on the original vehicle manufacturer’s original engine size as fitted to the make and model of the vehicle, and is **NOT** on the class cubic capacity limit.
Standard replacement pistons only are permitted.
- 1.5 Balancing.
The permitted engine’s original manufacture’s connecting rods, crankshaft, pistons, flywheel and clutch cover plate may be “Balanced”.

Lightening of components is prohibited. Excessive “Balancing” including multiple hole drilling in any single component will be judged as lightening and deemed illegal.

Note.

- i. One assembly/set consisting of one connecting rod and big end cap from the same cylinder must remain as standard (not balanced or lightened). The remaining units and components may be balanced to match.
- ii. Pistons: One Piston to remain as standard. The remaining pistons may be balanced to match. To be balanced by means of spot drilling only.
- iii. Conrods: To be balanced to manufacturer’s standard only. Removal of metal by spot grinding or spot drilling for “balancing purposes” is permitted for “little end” and “big end cap” only. Removal of metal from “H” section part of conrod prohibited.
- iv. The crankshaft, flywheel and clutch cover plate to be balanced by means of either-or spot grinding or spot drilling.
- vi. Crankshaft webs: A minimum of one crankshaft web must remain as factory finish. Crankshaft webs must not be chamfered, radiused, narrowed, knife edged, or smoothed or polished. If, in the opinion of the scrutineer, the crankshaft has been modified during the balancing process to improve its performance in other areas then it will be deemed illegal.

1.6 Water pump. – As Standard Production.

1.7 Camshaft.

Cam Lift See “Check Sheet”.

Cam/Valve Timing See “Check Sheet”.

1.8 Ignition System.

- a). The standard production Distributor and/or Distributor less (DIS) system / Electronic Control Unit (ECU) shall be correct for the engine fitted and must be retained in its entirety and remain in its original standard production form. It must be complete with the correct engine system sensors. E.g., Engine RPM & TDC etc.
The adaptation of any other distributors Distributor less (DIS) system or ECU, or sensors where they are fitted to other vehicle makes and/or models is prohibited.
Modification including disconnection and or removal and or sealing of any part of the vacuum advance system to prevent or enhance operation prohibited.
- b). The standard production Distributor and/or Distributor less (DIS) system / Electronic Control Unit (ECU) and associated sensors and Diagnostic “reader”/“interrogator” “plug in” connections must remain in their original standard production locations and must work. i.e., Be capable of operating when connected.
- c). The ECU shall be marked with identification showing the vehicle club prefix and vehicle number.
- d). The placing of or use of devices, whether within the wiring system or elsewhere, to provide false information to the ECU or any part of the fuel delivery control system is prohibited.
- e). For ECU’s that are fitted with a vehicle immobiliser facility, the particular ECU immobiliser function may be overridden or disconnected, provided no other function of the ECU is affected. ECU rewriting, remapping, chipping and or performance enhancing modification are not permitted. NASA shall not be held responsible for the performance or damage of the above unit.
- f). Ignition Leads & Spark Plugs & Coil – Free.

Note.

NASA reserves the right to:

- i. Remove and or retain the ECU fitted to the competitor’s vehicle and retain that unit for inspection.
- ii. Remove the ECU and substitute it for NASA supplied unit for a set time period. e.g., the duration of a race meeting or a stated number of races.
- iii. Remove the ECU and substitute it for a unit as used by another competitor.
- iv. Place a “Scrutineers Seal” onto the ECU for a specified period of time chosen by the Chief Scrutineer.
- v. Connect a “reader” to read and or check ECU settings.
- vi. NASA shall not be held responsible for the performance or damage of the above unit.

1.9 Cylinder Head.

The cylinder head MUST be the correct type for the engine concerned.

- i. Reconditioning of the cylinder head and its associated components must be carried out in accordance with the original manufacturer’s recommendations and accepted “reconditioning and repair” practice. Excessive removal of metal or reconditioning and or chamber radiusing that is carried out to the extreme will result in the components etc; being deemed as outside the Class regulations and thus illegal.
- ii. Cylinder Head Thickness. - See “Check Sheet”.
- iii. Cleaning:
Cleaning up or smoothing by removing metal or polishing of the original standard production finish is not permitted
Chemical and or “Ultrasonic” clean only permitted. “Sodium Bicarbonate (Soda Blasting)” cleaning permitted.

Inlet & Exhaust Ports

The inlet port and exhaust port surfaces, within the cylinder head, must remain as manufacturers original standard production finish and dimension.

A “3 angle cut” to valve & valve seat permitted.

Note.

- a). The top face of any valve insert fitted must be below or in line with the combustion chamber face.
- b). The depth of the valve insert must be not greater than that stated in vehicle check sheet.
- c). The cylinder head valve throat must remain as standard production diameter and “As cast” finish.
- d). When fitting a replacement valve insert it is not permitted to machine the valve throat beyond the depth of the new valve insert.
There must be a minimum of 1mm un-machined depth at the internal lowermost part or base of the insert.
- e). If a valve has 3 angle cut as standard, modification or machining to less than or more than 3 angles is prohibited.
- f). The “valve seat” must remain within the “area” and or “boundary limit” of the original standard valve seat.
- g). For both valve and insert “valve seat” the border line or edge between each individual “angle cut” must be clearly visible. The “merging” or “blending” and or joining together of the separate angle cut surfaces is prohibited.

- h). Reshaping and or cutting into the combustion chamber base or vertical surface adjacent to a valve insert as part of the “3 Angle Cut” process is prohibited.

Valve Head Diameter - See Check Sheet.

Valve Guides.

A standard production OE reconditioned and or replacement type only is allowed.
‘K-lined’ valve guides not permitted.

Cylinder Head Gasket.

Standard replacement types only permitted.

Cylinder Head Cam Cover.

Standard replacement types only permitted.

The external surface may be cleaned and polished and or have free decoration by painting or powder coating.

1.10 Air Box & Filter Box & Air Filter/Air Cleaner & Air Entry Ductwork.

The standard production air filter/cleaner casing must be retained.
The air filter/cleaner casing must be fitted in its standard production location.
Modification of air filter/cleaner casing prohibited.

Air Entry Pipe/Ductwork.

The standard production plastic ductwork including plastic plain duct (Carburettor)/plastic venturi duct (F. Injection) from Air Temperature Control valve to Air Cleaner housing must be retained and remain connected as standard production See Fig. 1. It is not permitted to fit the plain duct in place of the venturi duct or vice versa. All plastic duct/hoses must be securely fixed.

Air Filter/Cleaner element type.

Free.

However, an air filter must be fitted and secured within the standard production air filter casing in the standard production location.

All the air must enter the air filter/cleaner casing via the standard production entry orifice only.

1.11 Fuel Injection Unit/Throttle Body.

Type number and size is restricted.

The standard production Fuel Injection Unit/Injector/Throttle body must be retained in its standard production form. I.e. If a single-point fuel injection system is fitted, then it must be retained.

Modifications to Fuel Injection Unit/Injector/Throttle body prohibited.

The standard production single “accelerator” or “Throttle” pedal, including “Accelerator/throttle cable” must be retained to control the operation of the fuel delivery system to the engine.

The Fuel Injection Unit/Throttle body must be fitted with a throttle return spring of sufficient size, strength and movement such that the throttle closes once the ‘accelerator’ or ‘throttle’ pedal is released.

Note.

The accelerator cable/connection system must be sufficiently routed, shielded from any heat source, and lubricated to minimise the risk of seizure.

The fuel injector must be retained in its standard production form and be correct for the model and make of vehicle concerned. The fitting of an injector from a different model or make of vehicle is prohibited.

1.12 Carburettor.

Type number and size is restricted.

The standard production carburettor must be retained in its standard production form.

Modifications to carburettor including butterfly and choke system prohibited.

The standard production single “accelerator” or “Throttle” pedal, including “Accelerator/throttle cable” must be fitted to control the operation of the fuel delivery system to the engine.

The carburettor must be fitted with a throttle return spring of sufficient size, strength and movement such that the throttle closes once the ‘accelerator’ or ‘throttle’ pedal is released.

Note.

The accelerator cable/connection system must be sufficiently routed, shielded from any heat source, and lubricated to minimise the risk of seizure.

1.13 Engine Fuel System

a). The standard production engine fuel system shall be retained and remain in its standard production form.

The adaptation of any other systems, where they are fitted to other vehicle makes and/or models is prohibited.

b). Fuel Sensors shall be retained and remain in their standard production form. See Rule 1.8d.

c). Inlet Manifold.

The standard production inlet manifold shall be retained and remain in its standard production form, complete with standard production water hoses, sensors and connecting electrical wiring. The disconnecting or by-passing of the same is prohibited.

d). Fuel Pump.

The original vehicle manufacturers fitted fuel pump may be retained or removed.

Fuel pump and fuel regulator type and capacity free.

e). Carbon/Charcoal Canister.

The original vehicle manufacturers fitted “Evaporative carbon/charcoal canister” may be retained or removed.

If removed remaining hose connections must be blanked off with metal.

1.14 Engine Oil System.

The standard production engine oil system shall be retained and remain in its standard production form with the exception of:

a). The oil pick-up pipe may be repositioned and/or modified to function in the event of oil surge.

- b). The fitting of a sump oil baffle plate or plates permitted to minimise oil surge.
- c). Oil breather catch tank permitted.
- d). The fitting of an oil windage tray and or crankshaft scraper prohibited.

1.15 Component Sealing

The engine must have, available at all times, provision for the fitting of at least one readily accessible scrutineer's wire seal/tag, such that the fitting of the wire seal/tag prevents access to internal engine components.

A minimum of two adjacent engine cylinder head retaining studs or bolts must have a single 1.2mm (1/16") diameter hole pre-drilled in each of them.

- i. Where the method of cylinder head retention is by means of stud and locking nut the hole must be located above a cylinder head retaining locknut but below the top surface of the stud. (See Figs 2a. & 2b.).
- ii. Where the method of cylinder head retention is by means of a bolt the hole must be located through two adjacent edges of the hexagon head of the bolt.
- iii. Where cylinder head retaining studs and bolts are inaccessible, then a single 2mm (1/16") diameter hole must be pre-drilled in two accessible parts or areas of the engine.

The engine cylinder head, cam-cover must have, available at all times, provision for the fitting of at least one readily accessible scrutineer's wire seal/tag, such that the fitting of the wire seal/tag prevents access to internal engine components.

A minimum of two adjacent bolts must have a single 1.2mm (1/16") diameter hole pre-drilled in each of them.

1.16 Transmission/gearbox.

- a). The standard production transmission/gearbox, drive-shafts, drive shaft vibration dampers and wheel hubs shall be retained in their standard production location and shall remain in their standard production form.
- b). Standard production originals and NASA Scrutineers Committee permitted replacement transmission/gearbox drive-shaft and wheel hub components only must be used.

1.17 Gearbox/Transmission.

The transmission or gearbox must remain as per the manufacturer's original specification, complete with all gears including reverse gear and speedometer drives retained.

The 'Clutch' foot pedal assembly must be of standard production materials.

a). Gear Selector mechanism.

The standard production gear lever and gear selector system must be retained to control the operation of the transmission system "gear change" mechanism.

Mini 998cc - Rod Change Gearbox Gear Linkage: The Steady Shaft & Selector Rod must be steel. (Alloy prohibited).

Steering wheel mounted or operated gear change devices are prohibited.

"Quick Shift" gear lever or gear selector devices are prohibited.

b). Gear Ratios.

See "Check Sheet".

c). Differential.

The differential must be free revolving at all times.

d). Differential Turning Torque.

See "Check Sheet".

e). Crownwheel & Pinion Ratio.

As listed on the NASA Check Sheet.

Interchanging/Swapping of differential CWP ratios between gearboxes prohibited.

The correct differential CWP and ratio must be fitted in the correct gearbox.

f). Constant Velocity (C.V.) Joints.

The original standard production C.V. joints and flanges must be retained.

g). Oil Cooler - Transmission/gearbox.

Where a transmission/gearbox oil cooler is fitted as a standard production item it must be retained.

The fitting of a non-standard production or aftermarket type or fitting a cooler where one was not originally fitted is prohibited.

Junior drivers only.

The gear stick/lever may be extended rearwards from standard production to suit the stature and arm reach of a Junior Driver only.

Note.

Where a vehicle is to be driven by an adult competitor, any extensions fitted for a Junior competitor must be removed.

1.18 Transmission Location.

The transmission must be located such that it is connected to the engine as per original manufacturer's specification.

1.19 Clutch.

Standard production original and replacement clutch cover & plate only permitted.

The clutch cover plate may be balanced to the original manufacturer's standard only.

1.20 Engine Stabilisers.

The standard production engine stabilisers shall be retained in their standard production location and shall remain in their standard production form.

2 CHASSIS BODYSHELL

- 2.1 The bodyshell must be complete in its ENTIRETY, including all inner and outer wings, bonnet/engine cover, luggage compartment lid (boot/tailgate), doors, door pockets, rear seat bulkhead & backrest panel, rear inner wheel arches, rear seat pan, rear parcel shelf, boot floor, battery box/tray, rear valance and seams fitted.

Note.

i). Replacement panels.

Standard production or NASA permitted proprietary manufactured replacement body panels only to be used

The removal of any vehicle panel including engine cover/bonnet/luggage compartment lid/boot lid and replacement of the same with non-proprietary replacement metal panels is prohibited.

ii). Reinforcement of panels.

Reinforcement of panels is prohibited. Foam filling of panels is prohibited.

iii). Removal of bodyshell panels (Part of) and fixings.

Nil.

Tailgate hinges to be retained.

Removal of components or fixings on the body shell or its mechanicals is not permitted nor is the modification / relocation of same.

2.2 Vehicle Size & Dimensions – Restricted.

i. Vehicle Wheelbase – See Check Sheet.

ii. Vehicle Track. – See Check Sheet.

2.3 Rear passenger Compartment Doors & Tailgate.

The rear passenger's compartment doors (Nearside and offside) and tailgate must remain as original.

Removal of door tops (Window Frames) and or "skinning" prohibited.

2.4 Bonnet.

Removal or "skinning" of strengthening braces/ribs prohibited.

Bonnet hinges may be retained or removed.

2.5 Bumpers.

The original standard production front and rear bumpers must be retained and remain in the standard production location. Non standard or aftermarket front and/or rear bumpers prohibited.

The original bumper fixing brackets/tags may be retained or removed.

It is permitted to fit 2 replacement and or additional bumper support brackets, constructed of maximum of 25mm steel flat, 3mm thickness. Each with 8mm bolt fixings.

Note.

Failure to ensure that the bumper remains fitted during racing is a Black Flag (Race Disqualification) offence.

2.6 Aerofoils/spoilers - Restricted.

A standard production tailgate spoiler may be retained or removed.

2.7 Towing Eye.

The original standard production towing eye must be retained.

3. WINDSCREEN / GLASS - As Saloons General.

4 STEERING

4.1 The steering system from the steering wheel to the front wheels must remain as originally fitted to the vehicle make and model by the original vehicle manufacturer.

Junior drivers only.

The location of the steering wheel may be extended rearwards from standard production to suit the stature and arm reach of a Junior Driver only.

Note.

The steering wheel must be no further forward than standard production.

Where a vehicle is to be driven by an adult competitor, any extensions fitted for a Junior competitor must be removed.

4.2 Steering Column – Restricted.

The steering column must be as standard production and of correct standard production material.

It is not permitted to shorten nor lengthen the original standard production steering column.

The standard production column mounting bracket may be retained or removed.

If bracket retained - The original bracket must be fitted with padding for protection of driver legs.

If bracket removed - The column must be mounted from the front roll cage cross bar. The column must be mounted such that it remains at the standard production height and location.

Note.

The steering wheel height/angle adjustment bracket/lever must be securely fixed in its chosen height/angle location by welding or secondary fastening.

Junior drivers only.

The location of the steering column may be amended from standard production to suit the stature and arm reach of a Junior Driver only.

Note.

Where a vehicle is to be driven by an adult competitor, any amendments carried out for a Junior competitor must be removed.

4.3 Power Steering.

The standard production power steering systems i.e., rack and associated parts may be retained or removed and replaced with a non-power steering system.

If removed the steering rack must not be replaced with a "quick" rack.

For a non power steering model the replacement with a power steering rack is not permitted.

5 SAFETY HARNESS - As Saloons General.

6 SEAT - As Saloons General.

7 FIRE EXTINGUISHER - As Saloons General.**8 IDENTIFICATION - As Saloons General.****9 ELECTRICAL / INSTRUMENTS****9.1 Wiring Harness & Charging system.**

The standard production battery charging system including alternator must be retained.

9.2 Instrumentation and Gauges

The speedometer and associated speedometer cable up to the external gearbox connection point may be retained or removed.

The use of an engine/fuel system “Rev limiter” and/or gear “Shift light” system prohibited.

9.3 Battery type – Restricted.

A single 12 Volt electrical battery of a maximum dimension size that is equal or similar to the standard production item only must be used. Electrical capacity free.

Battery location – as Saloons General Rule 9.8.

10 FUEL**10.1 Fuel Pump.**

The original manufacturer’s fuel pump may be retained, modified or removed and replaced. Capacity free.

10.2 Fuel Regulator.

The original manufacturer’s fuel regulator may be retained, modified or removed and replaced. Capacity free.

10.3 Inlet manifold.

The standard production inlet manifold must be retained.

11 COOLING SYSTEMS

11.1 The standard production cooling system shall be correct for the engine fitted and must be retained in its entirety and remain in its original standard production form.

11.2 Radiator - Restricted.

The water-cooling system radiator must remain in the original standard production location and position, and be as originally fitted to the vehicle make and model, by the original vehicle manufacturer.

Standard production replacement radiator only permitted.

11.3 Secondary Expansion Tank.

A secondary water-cooling system expansion tank may be fitted. Maximum capacity 1 Litre.

11.4 Water pipes/Hoses.

The standard production water pipes/hoses may be retained or replaced with equal pipes/hoses.

Water pipes/hoses must be of metal or proprietary flexible hose. Silicone hoses permitted.

11.5 Oil Cooler/radiator type – restricted.

Engine oil cooler/radiator prohibited.

Oil/water fluid to fluid cooler/heat exchanger prohibited.

12 BRAKES

12.1 The standard production braking system must be retained, be correctly installed/fitted and be in good working order.

Standard production original and replacement brakes and brake components only permitted.

The ‘Brake’ foot pedal assembly must be of standard production materials.

Brakes may be subject to random spot checks of foot pedal operation whilst on the starting line.

Note.

i. The braking system must be as listed in the T.S.D. Manual for the vehicle used. Where a vehicle is listed as having “drum” brakes, then it is not permitted to fit “disc” brakes and vice-versa.

ii. The rear brake compensator may be removed.

iii. The practice of “Thinning” or lightening brake discs or drums or other braking components by “Thinning” and or “Diameter reduction” and or “Grooving”, “Slotting” or “Drilling” and or other machining is prohibited.

iv. Non-standard replacement after market brake drums prohibited.

12.2 Handbrake.

The original vehicle handbrake and or parking brake, including the cable and its associated components must be retained. The handbrake/parking brake components must be as original standard production, remain as original manufacture, be correctly installed/fitted, be in good working order and operate the rear wheels braking system only.

It must work sufficiently to prevent the vehicle from rolling. i.e., pushed or rocked by the inspecting scrutineer.

Conversion to a “Fly-Off” handbrake by repositioning standard handbrake components permitted.

The conversion of a cable system to hydraulic prohibited.

The original vehicle handbrake and or parking brake system is considered equal to a start line handbrake.

13 WHEELS**13.1 Wheels – Restricted.**

i. The wheels must be standard production or NASA permitted proprietary replacement wheel of a maximum of 5” (5J) width. Alloy wheels permitted. It is permitted to mix types (Steel/Alloy) of wheels on a vehicle.

- ii. The diameter of the wheel must be as standard production - 13" diameter.
- iii. All axles/hubs on the vehicle must be fitted with wheels that are of the same diameter. The use of different wheel diameter sizes on the offside and nearside of the vehicle is prohibited.
- iv. Offset/Inset is restricted. The wheel rim must not protrude more than 15mm beyond the original wheel arch.
- v. The use of wheel adaptors and or combined adaptor and spacer to fit wheels of a different PCD from standard is not permitted.
- iv. "Beadlock" and/or Beadlock type and "Billet" and or "Billet type" wheels are prohibited.

13.2 Wheel Spacers – Restricted.
Thickness Size 3mm maximum.

13.3 Wheel Studs
It is permitted to change the standard wheel studs to a longer in length steel type only to enable correct wheel fitment. Excessive length types prohibited.

14 TYRES

14.1 Tyre Size - Restricted.
145/70 x 13.
155/70 x 13.

15 EXHAUSTS

15.1 Exhaust System – Restricted.
The standard production original exhaust manifold and system must be retained in their entirety and remain in their original standard production location/position and form.

Note.

- a). "Single" (One) or "dual" (Two) silencer box replacement exhaust systems permitted.
- b). The fitting and/or use of any non-standard production material or covering or coating or device that controls exhaust temperatures or affects exhaust scavenging is prohibited.
- c). Exhaust mounting rubbers may be modified to retain vehicle exhaust system.

15.2 Fuel Injection – Lambda Sensor.
For vehicles fitted with Fuel Injection as a standard production item the Exhaust Lambda (Oxygen) Sensors shall be retained in their standard production location and remain in their standard production form.

15.3 Catalytic Converters.
Catalytic Converters may be retained or removed. If removed the space remaining in the exhaust system pipe-work, following removal of the catalytic converter must be filled in with a piece of exhaust pipe that is of round circular section of a diameter that is the same as or not greater than the remaining standard production exhaust pipe-work.

Note.

The use of a proprietary replacement system from the exhaust manifold connection through to the rear incorporating the standard silencer but without a catalytic converter is permitted. Such a system must match the standard production exhaust system in pipe internal diameter and shape/profile including twists and turns.

15.4 The exhaust system must not protrude beyond the vehicle bodyline. The rear tailpipe may be shortened / cut, at any point after the standard production rearmost support bracket, to prevent it protruding beyond the vehicle bodyline. Shortening point is from 25mm after rear silencer box.

16 SAFETY SHIELDS

16.1 Sump Guard.
Sump Guard prohibited.

17 SUSPENSION

17.1 Suspension type is restricted.
The original manufacturer's standard production suspension system must be retained.
"Concentric Strut Top" mountings prohibited.

Note.

Front suspension sub-frame and components including anti-roll bar must remain as standard production.
Rear beam axle, torsion bar, anti-roll bar and trailing arm assembly/components must remain as standard production.

17.2 Wheel Camber & Wheel Castor.
It is not permitted to alter the camber / geometry of the suspension.
See Check Sheet.

Note.

Slight deviation from standard as a result of race track conditions is acceptable.
Excessive deviation of the camber angle from standard prohibited.

Wheel Alignment (Toe in/out). – Restricted.

Slight deviation from standard as a result of race track conditions is acceptable.
Excessive deviation from standard prohibited.

17.3 Front and Rear Suspension Springs – Restricted.
Standard production original and standard replacement suspension springs only are permitted.
It is permitted to shorten the permitted suspension springs to achieve an appropriate ride height following removal of interior trim – See rule 17.6.
"Concentric Strut Top" mountings prohibited.

- 17.4 Suspension Dampers – Restricted.
Standard production original and standard replacement front and rear dampers that are of the oil and/or gas filled type only are permitted.
Standard production replacement units as manufactured by: “KYB – Excel/Ultra”; Monroe – Original/Reflex” permitted.
Bilstein’, ‘Spax’ or Gmax or similar equivalent and or equal type units prohibited.
- 17.5 Strut Brace – Restricted.
A proprietary manufactured “Strut Brace” may be fitted transversely between the engine compartment suspension top turret housings.
- 17.6 Vehicle ride height.
Any car where the ride height is felt to be high or to low to enhance the cars performance will be ordered and required to alter its ride height in respect of safety. Failure to comply will result in disqualification and disciplinary action.
No minimum or maximum ride heights will be given, except for specified vehicles.
The ride height will be compared to cars in full road spec trim.

18 PROTECTION

- 18.1 Rear Protection – Restricted.
Rear protection prohibited.
- 18.2 Distributor Protection – Restricted.
Distributor protection prohibited.

19 BALLAST – All Vehicles

- 19.1 The fitting of and or use of ballast is prohibited.
Note.
The use of over large or inappropriate components or structures may be deemed as ballast and prohibited.

20 VEHICLE CHECK SHEETS – CLASS 1.

All VEHICLES.

NASA reserves the right to designate the information reference source and the method of component checking and to revise the check sheet data at any time.

Note.

The ‘Vehicle Check Sheet’ data and other designated information source will be used in conjunction with the particular vehicle Palgrave / Glasses Guide Technical Services Data Sheet as a reference when checking the eligibility and legality of the vehicle and or any of its components.

Components used must be NASA Scrutineers Committee permitted “Standard production” or “Standard production replacement” items.

Components specifically manufactured for and or fitted to “Rally”, “Homologation” “Motorsport”, and “Competition” including low volume/number (e.g., less than 5,000) “Limited edition” and or “Special” type models or variants of vehicle by the original vehicle manufacturer or manufacturer appointed organisation or company are prohibited.

The replacing of any steel component with a steel or non-steel lightweight material component is prohibited.

In the event of any doubt a Scrutineer must be contacted for clarification before using the component concerned.

In order that an engine, engine ancillaries, and gearbox may be checked to ensure standard components have been used, given below are a set of dimensions and details.

THESE DIMENSIONS GIVEN ARE TO CHECK THE LEGALITY OF THE VEHICLE, ENGINE, ENGINE ANCILLARIES, AND GEARBOX, NOT TO BUILD A VEHICLE, ENGINE, ETC. TO.

All dimensions given, either maximum or minimum, include tolerances to cover all manufacturing deviations.

Any standard component checked will be within the dimensions given, hence any deviation at all above a maximum or below a minimum shows an ILLEGAL COMPONENT.

As all dimensions given include a tolerance for manufacturing deviations, where an engine is checked and found to have 10% of dimensions, to the absolute limit given, this unit will be deemed ILLEGAL.

The suspension dimensions have been given so that if it is felt a vehicle may be outside variations through normal wear and tear, a check may be carried out to ensure standard components have been used and correctly fitted.

DIMENSIONS AND DETAILS ARE GIVEN IN ORDER OF AN ENGINE STRIP and or VEHICLE CHECK.

VEHICLE WEIGHT.

All Vehicles – Free.

SPECIFIED VEHICLES.**VEHICLE CHECK SHEET CLASS 1 – CITROEN AX, SAXO & PEUGEOT 106 954cc**

Engine type: C1A (type TU9/K) (Carb). CDZ & CDY (TU9/M) (Inj).

CYLINDER HEAD

Head Thickness Minimum = 110.05mm.

954cc Cylinder Head Casting number 'xxxxxxx110'

Cylinder Heads marked "M+" and or of the 1124cc engine are prohibited.

Inlet port diameter (as measured at the gasket face) = 25mm.

VALVE HEAD DIAMETER.

Inlet valve head diameter (Max) = 34.8mm.

Exhaust valve head diameter = 27.90mm.

VALVE LIFT & VALVE TIMING.

The following valve lift & valve timing combinations only are permitted.

Maximum Valve Lift shall be:

Inlet: = 8.0 mm. Exhaust: = 8.0 mm.

VALVE TIMING.

Either 9°16' BT/11°10'AB/31°21'BB/6°55'AT.

Or 2°3' BT/21°56'AB/39°36'BB/0°53'AT.

VALVE GUIDES

A standard production OE or NASA permitted reconditioned and or replacement type only is permitted.

Overall Length/Depth of valve guide = 47.5 +/- 0.3mm.

Internal Diameter of Valve Guide = 7mm.

Depth of Valve Guide from top to head face.

Inlet = 14.57 +/- 0.1mm.

Exhaust = 14.07 +/- 0.1mm.

VALVE SPRINGS.

Valve Spring Free Length = 54mm.

ENGINE BLOCK

Check if top surface has been machined – "Decked", Skimmed, Re-faced.

PISTONS.

Pistons to be as standard production original and replacement complete with identification marks.

Bore = 70mm.

Piston Diameter = 69.94mm.

(Oversize's A+0.01mm, B+0.02mm, C+0.03mm).

Piston skirts must not be modified or shortened.

No of Piston rings = 3.

The omission of any standard production piston ring is prohibited.

Piston Liner Internal Diameter = 70.00mm.

(Oversize's A+0.01mm, B+0.02mm, C+0.03mm).

CRANKSHAFT

Crankshaft Stroke = 62.00mm.

CARBURETTOR

Carburettor Type = Weber 32 IBSH 16/100.

Or Solex 32 PBISA 16 412.

Note.

It is not permitted to use a carburettor from the 1124cc or 1360cc engines on the 954cc engine.

FUEL INJECTORS.

Fuel Injection Single Point = Bosch mono motronic MA3.0 / MA3.1

Injectors must be standard and correct for engine.

Injectors from other models and or vehicles prohibited.

"Rev Limiters" must operate at standard production rpm maximum.

REV LIMIT.

"Rev Limiters" must operate at standard production rpm maximum

AIR INTAKE DUCTS.

Check for holes drilled and slits cut into air box & duct air intake system.

FLYWHEEL AND CLUTCH.

The starter ring gear must be the correct type for the flywheel used.

Standard production original and replacement clutch only permitted.

MAIN BEARINGS.

Standard production original and replacement types for the particular engine block used only permitted.

GEARING FULL STRIP CHECK.

During a full strip, given below are the numbers of teeth in gearbox.

MA4 - 4 Speed.

1st 3.42:1 12/41 teeth.
 2nd 1.81:1 21/38 teeth.
 3rd 1.13:1 31/35 teeth.
 4th 0.81:1 43/35 teeth or 1.05:1 (37/39 teeth).

MA5 - 5 Speed.

| | | |
|------------------------|--------------|--------------------------------------|
| Either | | Or |
| 1 st 3.42:1 | 12/41 teeth. | 1 st 3.42:1 12/41 teeth. |
| 2 nd 1.95:1 | 20/39 teeth. | 2 nd 1.81:1 21/39 teeth. |
| 3 rd 1.36:1 | 28/38 teeth. | 3 rd 1.276:1 29/37 teeth. |
| 4 rd 1.05:1 | 37/39 teeth. | 4 rd 0.975:1 40/39 teeth. |
| 5 th 0.85:1 | 41/35 teeth. | 5 th 0.767:1 43/33 teeth. |

Final Drive Ratio.

3.58:1 or 3.76:1 or 4.06:1 or 4.286:1 (14/60 teeth).

DIFFERENTIAL TURNING TORQUE

The differential must have a turning torque of a maximum of 3 lbf/ft (36 lbf/in) (4 Nm) at all times, when measured at the wheel hub. i.e. When the transmission is set to neutral and the nearside wheel and tyre raised off the ground whilst the offside wheel and tyre assembly remains on the ground, and vice-versa, then when a torque measuring device is applied onto the wheel hub nut the maximum turning torque of the differential and driveshaft assembly must not exceed the stated maximum regardless of the temperature of the unit.

See T.S.D Manual Sheet for other measurements.

BRAKES**Models without ABS/Power Steering:**

Front Brake Disc - Solid: - Standard production diameter = 238mm.

Front Brake Disc - Solid: - Standard production thickness = 8.0mm Maximum. 6.0mm Minimum.

Models with ABS/Power Steering:

Front Brake Disc - Solid: - Standard production diameter = 247mm.

Front Brake Disc – Solid: -Standard production thickness = 10.0mm Maximum. 8.0mm Minimum.

Front Brake Disc - Vented: - Standard production diameter = 247mm.

Front Brake Disc – Vented: -Standard production thickness = 20.4mm Maximum. 18.4mm Minimum.

SUSPENSION.**Citroen AX.**

Front Suspension Coil Spring: Free length = 339mm.

Spring Wire Diameter = 11mm.

Front Wheel Camber = -0° 25' -/+30' Max.

Rear Wheel Camber = -0° 9' -/+ 20' Max.

Saxo.

Front Wheel Camber = -0° 9' -/+30' Max.

Rear Wheel Camber = -0° 59' -/+ 20' Max.

Peugeot 106.

Front Wheel Camber = -0° 14' -/+30' Max.

Rear Wheel Camber = -1° 34' -/+ 30' Max.

VEHICLE TRACK.

As manufacturers original specifications + 6.0mm. (3mm each side).

WHEELBASE.**Citroen AX.**

2280mm (89.8").

Saxo & Peugeot.

2385mm (93.9").

TYRES.

Check correct tyres fitted.

145/70 x 13.

155/70 x 13.

See T.S.D Manual Sheet for other measurements.

NASA reserves the right to amend the check sheet at any time.

DRAWINGS

DRAWING No. 1 - CYLINDER HEAD INLET & EXHAUST PORTS.

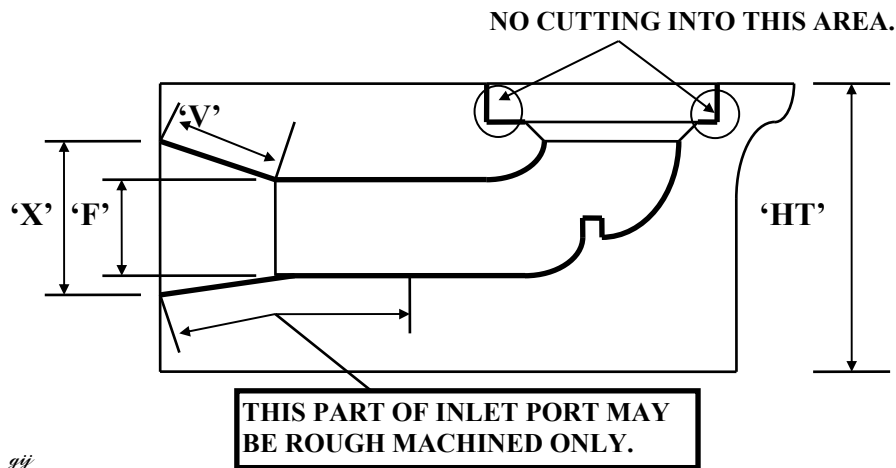

gij

The surfaces of the inlet and exhaust ports must remain as produced by the original vehicle manufacturer. i.e., "Rough as cast"
 Polishing and or Machining and or Grinding and or Reshaping of surfaces other than shown is prohibited.
 "3 Angle cut" to valve and valve seat permitted.
 Reshaping and or cutting into the combustion chamber base adjacent to a valve insert as part of the "3 Angle Cut" process is prohibited

DRAWING No. 2 CYLINDER HEAD INLET & EXHAUST PORTS.

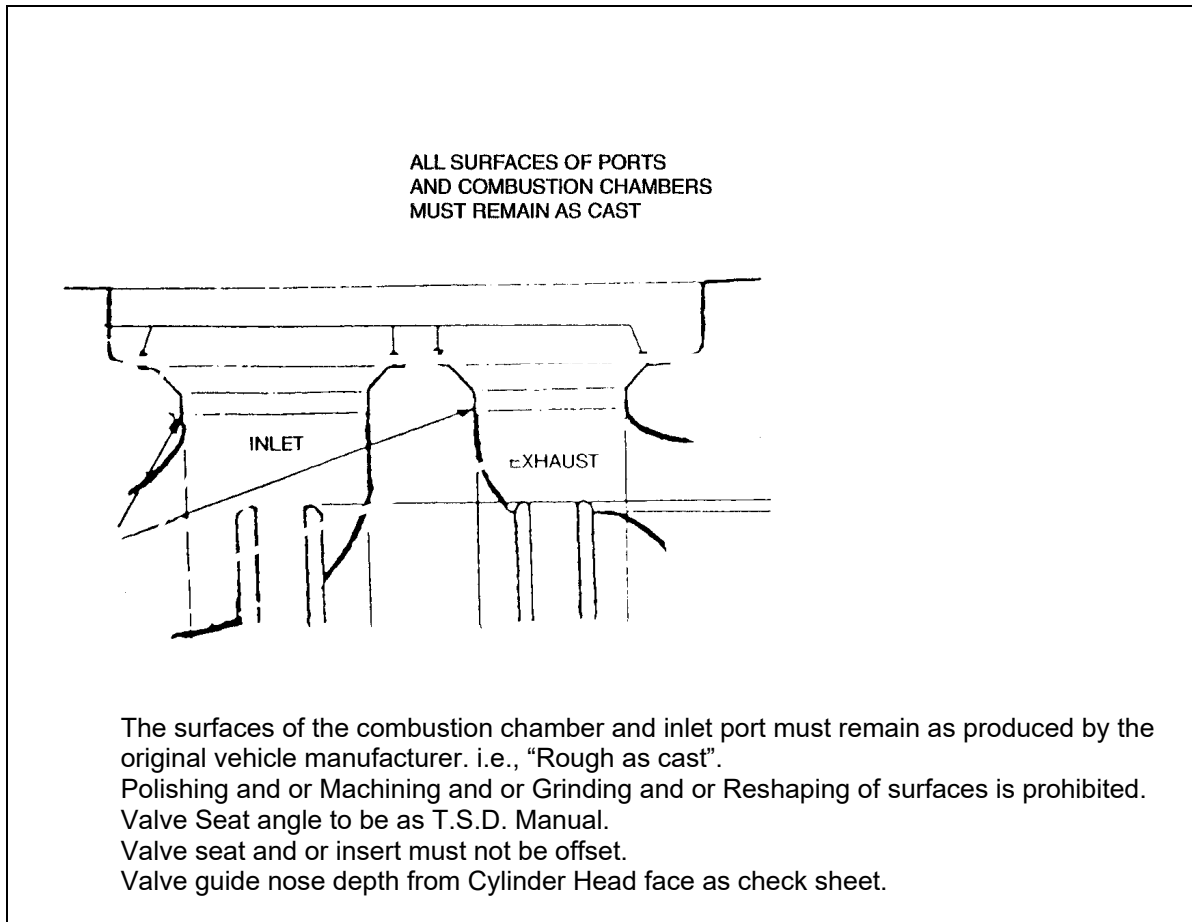
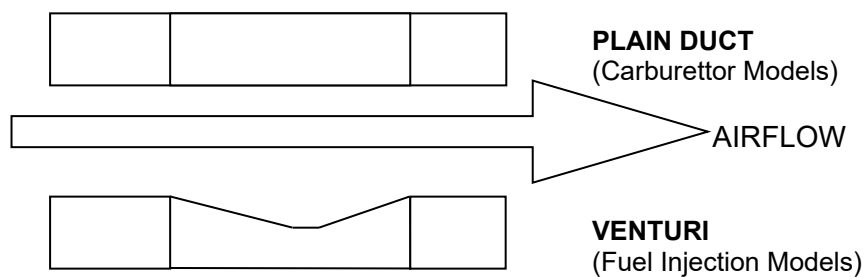

FIGURE 1 CLASS 1 - AIR INTAKE DUCT REQUIREMENT.
Citroen AX & Saxo, Peugeot 106



It is not permitted to fit Venturi Duct to Carburettor intake duct and or Plain Duct to Fuel Injection intake duct.

FIGURE 2a – ENGINE SEALING – As Fig 12a – Saloons General.

FIGURE 2b – ENGINE SEALING - As Fig 12b – Saloons General.

The construction rules in this book are intended for use by Autograss cars taking part in Autograss events as defined by the NATIONAL AUTOGRASS SPORT ASSOCIATION on a natural surface and are not necessarily considered safe for other forms of motor sport.

Drivers are advised that if they intend using their cars at events, other than events as defined by the NATIONAL AUTOGRASS SPORT ASSOCIATION They should ensure that their cars comply with the organiser's construction rules.

® AUTOGRASS IS A REGISTERED TRADEMARK OF NATIONAL AUTOGRASS SPORT ASSOCIATION

© COPYRIGHT NATIONAL AUTOGRASS SPORT ASSOCIATION LTD 2025