

**ASSOCIATION OF
AUTHORISING
BODIES**



RULES & REGULATIONS

2020 EDITION

SPECIALS

GENERAL



"The National Autograss Sport Association Ltd (NASA) reserve the right to alter/amend the Rule Book as required, and that NASA has the right to review and amend any Class or Construction Rules at the end of each racing year."

**VALID FROM JANUARY 2020
UNTIL FURTHER NOTICE**

ALL PREVIOUS EDITIONS ARE INVALID

IT IS THE RESPONSIBILITY OF THE DRIVER/CONSTRUCTOR TO ENSURE THAT ALL VEHICLES CONFORM FULLY TO THE REGULATIONS AND RULES CONTAINED WITHIN THIS RULEBOOK.

IF THE REGULATIONS AND RULES DO NOT STATE THAT "YOU CAN DO IT" THEN IT MUST BE PRESUMED THAT IT CANNOT BE DONE.

SPECIALS

GENERAL

GENERAL BASIC CONSTRUCTION RULES**SPECIALS**

INDEX	PAGE
CLASSES	1
LICENCE	2
DEFINITIONS	3
VEHICLE CONSTRUCTION RULES	5
1 Statement of Conformity	5
2 General	5
3 Technical Notes	6
4 Engine Specification	6
5 Engine Sealing & Capacity Labelling	6
6 Engine Location	6
7 Transmission	7
8 Vehicle Dimensions & Weight	7
9 Steering	8
10 Chassis & Roll Cage	9
11 Chassis Panels	11
12 Safety Shields & Guards	13
13 Protection	14
14 Suspension	14
15 Windscreen/Glass	15
16 Safety Harness	15
17 Seat	16
18 Fire Extinguisher	17
19 Vehicle Identification	17
20 Electrical & Instruments	17
21 Fuel	18
22 Cooling Systems	20
23 Brakes	20
24 Wheels	21
25 Tyres	22
26 Exhaust & Silencing	23
27 Ballast	23
28 Check Sheets	23
FIGURES	24
SILENCING	46
TABLE	46
NOISE CHART	47

FOR INDIVIDUAL CLASS SPECIFIC CONSTRUCTION RULES
(i.e. Additional requirements specific to each class of vehicle).
SEE INDIVIDUAL CLASS SPECIFIC – REQUIREMENTS RULES.

CLASSES

- Class 1** Under 1000cc Front Wheel Drive Saloons of specified type and manufacturer.
Class 2 Up to 1300cc, limited modification vehicles
Class 3 Over 1421cc, front-engined rear wheel drive, modified saloons
Class 4 Up to 1130cc modified vehicles
Class 5 1131cc - 1420cc modified vehicles
Class 6 Front wheel drive modified vehicles – Restricted minimum capacity.
Class 7 Over 1421cc rear wheel drive, modified vehicles
Class 8 Up to 1420cc Specials
Class 9 1421cc - 2070cc Specials
Class 10 Over 2071cc Specials
Junior Specials Under 1200cc Vauxhall Corsa Engined Special Restricted Drivers Only.

Ladies Classes - Recommendations for Club/League Racing.

It is recommended that Ladies are given the same amount of racing as Men.

- Class 11** Classes 1 & 2 will race together duly handicapped/staggered.
Class 12 Classes 4, 5 & 6 will race together duly handicapped/staggered.
Class 13 Classes 3 & 7 will race together duly handicapped/staggered.
Class 14 Classes 8, 9 & 10 will race together duly handicapped/staggered.

Class Races - Maximum amount of vehicles allowed on a single straight-line start is, (refer to Members Handbook Track Construction General, rule 2 regarding track width):

All Classes = 8 Vehicles.

Note. Where classes are mixed the maximum number of vehicles allowed on a straight-line start reduces to the lower number applicable to the classes above. E.g.: Specials & Saloons mixed 8 vehicles on a straight-line start.

LICENCE

1. All drivers must hold a NASA Licence obtained through an Affiliated Autograss Club, before they can race. (For a listing of affiliated Clubs see NASA Website and/or NASA Fixture List).

The driver's NASA issued racing Club and League prefix and number identification shall be confirmed within the NASA Licence.

The NASA permitted number identification shall be a figure 3 numerical figure from 1 to 999. For any number less than 1 or greater than 999 an application must be made to NASA for permission to be allocated the number before it can be used. It is not permitted to prefix any number identification by the figure zero (0) e.g. 0001, 001, 01 ... etc.

Note: Racing on pink application slips will not be allowed.

2. A person over 18 years of age may be issued with a NASA competition licence.
 - 3*. A person under 18 years of age and over 16 years of age may be issued with a NASA Competition Licence provided that the official letter of consent to compete is received from his/her parent or legal guardian.
 - 4*. A person under 16 years of age and over 12 years of age may be issued with a NASA Junior Competition Licence provided that the official letter of consent to compete is received from his/her parent or legal guardian.
 - 5*. All NASA Competition Licence holders fewer than 18 years of age and over 12 years of age must produce their copy of the letter of consent signed by their parent or legal guardian to any official when required.
- * **All Application Forms and Letters of Consent for under 18's are available from your Club Secretary.**
6. A Men's Licence entitles you to race in Men's Classes only, and Men's Championships.
 7. A Ladies Licence entitles you to race in Ladies Classes only, and Ladies Championships. (A lady may apply for a Men's Licence, and then **MUST** race in Men's Classes only.)
Note:
A Lady competitor will not be allowed to change her competition licence (i.e. Men's to Ladies or Ladies to Men's) during any one season.
 8. A Junior Special Vehicle may be raced by a Men's or Ladies competition licence holder at single day events only.
 9. **Junior Drivers** must use **either** a Class One vehicle and **or** a Junior Special vehicle **only**, in Junior races. They **must not** compete with Men or Ladies, or race any other Class of vehicle See relevant rule books for Junior Licence details.
 10. A competitor/driver must produce his/her licence to any official when required.
 11. NASA reserves the right to refuse a licence to any driver who has been refused a current road licence for medical reasons.
 12. NASA also reserves the right to refuse or cancel any issued identification numbers and letters. Frivolous or obscene number/letter combinations are prohibited.
 13. All licences must have a current photograph of the Licence Holder affixed to the Licence at all times.
 14. If you lose your Licence, please contact your own Club Secretary for details of reapplication.

GENERAL INSTRUCTIONS FOR APPLYING FOR A NASA LICENCE

No one is allowed to race in a NASA Class until they have received their licence or a day licence has been issued.

1. You must obtain an Application Form for your Licence from your Club Secretary, giving to that Secretary your subscriptions for your Licence. The Club Secretary must sign and date the form and also stamp it with the Club Stamp, if the club has one.
2. You will also receive an envelope with the address of the person to whom you must send the Application Form.
3. The Form is in quadruplicate and when filled in you should hand the yellow copy back to your Club Secretary, keep the pink copy for yourself and send the two white forms to the Registration Secretary for your League together with a STAMPED SELF-ADDRESSED ENVELOPE. FAILURE TO SEND A STAMPED SELF-ADDRESSED ENVELOPE WILL RESULT IN YOUR LICENCE NOT BEING ISSUED.
4. When filling in the Application Form, please print all the details and mark the appropriate Licence that you are applying for. A Full Men's is for a Man's Licence and likewise with the Full Ladies, although if a lady wishes to race with the men only and wishes to compete at the Men's Championships and not at the Ladies' Championships then she too must apply for a Full Men's Licence. A Mechanics Licence is for persons who wish to be mechanics and/or officials and a Membership card is for Officials. (If applying for a Junior Licence then the Application Form must be countersigned by a Parent or Guardian.) A copy of the NASA letter of consent for Juniors and drivers under 18 when they apply for a licence, must also be sent with the application form, otherwise the application will not be processed.
5. If you have any problems regarding the above, and with your Application then please contact the person to whom you will send or have sent your Licence application.

PLEASE NOTE FAILURE TO COMPLETE THE APPLICATION FORM CORRECTLY WILL RESULT IN IT BEING RETURNED TO YOU UNTIL IT HAS BEEN COMPLETED SATISFACTORILY.

DEFINITIONS**Active /Adaptive/ semi-Active Suspension**

The vertical movement of a vehicle's wheels relative to the chassis or vehicle body is controlled by an automatic onboard system/device in conjunction with electrical/optical/hydraulic sensors and control unit/computer to detect/monitor body and or chassis movement in relation to the surface the vehicle is being driven upon.

Aerofoil/Spoiler - Any device or part of a vehicle which affects airflow over a vehicle to create an aerodynamic advantage.

Authorised Personnel – Driver, Mechanic, Marshal, Scrutineer or Official who has signed on.

Ballast - Non-functional material added or fixed to the vehicle to increase weight.

Bulkhead A Bulkhead is a partition or panel separating any two vehicle compartments.
e.g. Engine compartment and driver's compartment.

Class - Vehicles grouped together governed by specified Rules.

Cross-Over Rule - Vehicles must hold a straight line until the appropriate marker has been passed.

CWP/cwp - Crown Wheel Pinion.

Driver's Compartment – Specials.

The driver's compartment is the area within the vehicle chassis occupied by the vehicle driver.

It is deemed to begin at an imaginary line, across the vehicle from the front face of the nearside rear roll cage upright to the front face of the offside rear roll cage upright.

It is deemed to end at an imaginary line across the vehicle forward of the fully depressed foot control pedals.

Enclosed Space - An area which is fully enclosed by material such to prevent access to any point within that area for fire extinguishant.

Engine. - An internal combustion device for the production of motive power, consisting of one or more fuel combustion chambers with a common rotating internal output shaft, as produced by a NASA Recognised and permitted manufacturer.

Engine Ancillaries – Carburettor/Throttle Bodies/Injection, inlet manifold, exhaust manifold, exhaust system.

Event – A continuing competition held over a period of one or more days.

False Start – Vehicles commencing a race before the start of race signal is given.

Fit for purpose - Whilst racing, vehicle components and or construction and or fixings may be subject to severe shock and stress loading. NASA reserves the right via an appointed Official and or Scrutineer to reject a component and or construction and or fixings, deemed as not fit for purpose and unsuitable the "Autograss racing environment"

Gauge - In all references to measurements, "gauge" refers to British Standard Wire Gauge. (See Table for gauge details)

NASA – all references to NASA refer to the National Autograss Sport Association Ltd.

Official Vehicle – Vehicles such as Tractors, Breakdown vehicles or other vehicles in the custody or control of the Club/League.

Oil tank – A container for the storing of oil including breather system catch tank, oil reservoir and or dry sump tank.

Padding/Cushion.

An enclosed non-metal item such as cloth bag filled with soft material stuffing to support or ease or "fill in" gap between driver body and seat.

Parent – in the context of these rules is the natural parent of any licence holder who is under 18yrs of age. It does not include a step parent, the "partner" of a natural parent or a guardian who has not been appointed as such by a court. It does include a "Legal Guardian" who will be a person who has been appointed by a court to act as such.

Passive suspension.

The vertical movement of a vehicle's wheels relative to the chassis or vehicle body is determined entirely and solely by the surface the vehicle is being driven upon. i.e. This occurs without any assistance and or action by any automated system and or vehicle driver.

Panel. (Including "Panelled" and or "Panelling") -

Sheet metal used to clad and or cover the chassis structure and roll cage as specified & required. Material to be either Steel sheet or Non Ferrous metal/Aluminium sheet.

Minimum Thickness: Steel sheet = 22 Gauge (0.71mm (0.028")).

Non Ferrous Metal or Aluminium Sheet = 1mm (0.40").

Private Vehicle – Vehicles that are not owned by the Club/League and not in the custody or control of the Club/League.

Pump Fuel - A type sold to the public in the United Kingdom at roadside Filling Stations. L.P.G. / Methanol are not allowed.

Proprietary / Proprietary Manufactured. – An item or component that is produced, manufactured and marketed by a NASA recognised manufacturer.

Re-Run - A repeat of the previous race minus exclusions and non-runners, if any, with original grid positions and any penalties imposed in the original race being maintained.

Rev Limiter – A device that controls and or restricts engine maximum RPM.

Silhouette - The silhouette is the shape of the vehicle when viewed from the front, back and side elevation, and when viewed from the top.

Track - The area within the confines of the spectator barrier.

Traction / Launch Control - An automatic and/or electrical and/or optical and/or mechanical and/or pneumatic and/or hydraulic method of controlling:

a. The vehicle driving wheel or wheels rotational speed in relation to the distance travelled by the vehicle.

b. The vehicle suspension system in relation to differing start-line settings and racing settings.

By means other than direct human driver action upon the accelerator and/or throttle and/or engine fuel delivery activator.

1. STATEMENT of CONFORMITY.

Only methods of construction and modifications as listed are permitted. Any modifications, other than those permitted, and or listed within the Vehicle Construction Rules are specifically excluded. i.e. If the rules do not “say” that a modification is permitted then it is not allowed.

In the event of any doubt a NASA Scrutineer must be contacted for clarification.

Competitors **must** ensure that their racing vehicle conforms to NASA Rules and Regulations.

Where a competitor is less than 18 years of age the responsibility is shared with the parent/guardian.

2. GENERAL

2.1 A Special is defined as a single seat, open wheeled, purpose built racing vehicle for Autograss Racing on an unsealed surface only and constructed in accordance with the following construction regulations.
A Special must not be capable of seating any person other than the driver.

2.2. All driver controls must be operated from, and remain within, the drivers compartment at all times.

2.3. Driver size & Stature.

The vehicle must be constructed to suit the competitor driver size and stature in all respects.

If it is considered that a particular vehicle is unsuitable for a driver (whether Junior or Adult), given the person’s size or stature then NASA reserves the right via an appointed Official and or Scrutineer to deem that the person concerned will not be permitted to race that vehicle.

Note.

The underside of the top bar of the roll cage must be not less than 75mm (3") above the helmet of the seated driver.

2.4. Component Compliance.

NASA reserves the right via an appointed Official and or Scrutineer to request a competitor (**Note.** For persons under 18 years of age this includes the parent/guardian), to remove any component part of the vehicle for inspection and or measurement for compliance with the regulations.

The removal of the component shall be carried out by the competitor concerned and or competitor’s mechanic under the supervision of the appointed Official and or Scrutineer.

Refusal to comply with such a request and or provide the item for inspection will immediately deem the vehicle as being in contravention of the NASA vehicle construction rules and make the competitor and or member concerned subject to disciplinary action.

Component Sealing and Purpose.

Seals can be fitted to any component or part of a vehicle by a NASA designated official.

The purpose of sealing is to prevent any component or parts being substituted for another unit prior to the inspection of the unit by a designated official.

Refusal to comply with a request to fit a “Seal” will immediately deem the vehicle as being in contravention of the NASA vehicle construction rules and make the competitor and or member concerned subject to disciplinary action.

Seal Removal.

Once a seal has been placed by the duly appointed official the competitor and or member concerned must seek permission to remove or “Break” such seals. A seal must not be removed without the express permission of the NASA designated official or NASA Chief Scrutineer.

The person that removes or “Breaks” a seal must be able to demonstrate to any official that permission has been granted for seal removal.

The unauthorised removal or “Break” of a seal will immediately deem the vehicle as being in contravention of the NASA vehicle construction rules and make the competitor and or member concerned subject to disciplinary action.

2.5. Component Retention/Confiscation.

NASA reserves the right via an appointed Official and or Scrutineer to retain any component part of the vehicle for inspection and or measurement for compliance with the regulations. NASA reserves the right to designate the information reference source and the method of component checking. Such components may be returned to the competitor concerned or confiscated at the discretion of the NASA Official Scrutineer.

2.6. The vehicle must be maintained in good order. Vehicles in poor condition may not be permitted to race at the discretion of the scrutineer.

2.7. The vehicle must be able to drive to scrutineering and to, around and within the pit area without any assistance. If the vehicle suffers damage due to an on track incident then assistance as necessary to return it to the pit area for repairs and or to transporter for removal from meeting is permitted.

2.8 Driver Arm Restraints.

It is the responsibility of all competitors to ensure that their arms are restrained from extending outside of their vehicle in the event of an accident or roll. This must be done by the use of either a permitted arm restraint or window net or by their seating position within their car.

It is the driver’s responsibility to ensure that any adjustments are correct and that the necessary equipment is properly fitted. Drivers will be checked in their cars by scrutineers.

Officials will monitor the use of this equipment as they do with other safety equipment.

Drivers who appear to be flagrantly ignoring the intended safety considerations of these rules will be penalised.

Note:

a). All restraint systems must not impede, entangle, unlock, unfasten, disengage nor prevent the correct reach and or access to and or operation of any safety harness or driver operated vehicle controls (e.g. Steering. Ignition switch. Cut off switch. Gear lever, etc.).

Arm restraints should be released by the single opening of the seatbelt fastening mechanism.

It is the competitor's responsibility to ensure compliance when making the choice of restraint system.

The restraint System must be in the form of either "Arm Restraints" or "Window Webbing".

The both also may be used together.

Proprietary manufacture Arm Restraints for motorsport only permitted. Simpson/Sparco/TRS Arm Restraints permitted.

For window webbing see rule 11.8.

- b). It is the Competitors responsibility to contact a scrutineer and or designated official to confirm the particular restraint system form of construction is eligible. i.e. permitted by the NASA Scrutineers Committee **before** using it and or them.
- c). When a restraint system and or construction is inspected and is not to the satisfaction of a scrutineer and or designated official then it is deemed as being in contravention of the NASA vehicle construction rules and will not be eligible for use. Therefore it must be removed immediately. The competitor is not permitted to race until a permitted "Restraint System" is used.
- d). The "Restraint System" form of construction must be only as permitted by NASA. The types of construction will be subject to regular review by NASA to ensure suitability for Autograss racing.

NASA reserves the right to amend the permitted "Restraint System" construction requirements at any time.

- 2.9. The Scrutineer's decision, as to the eligibility of any component or part and or suitability of a vehicle for racing is final.

3 TECHNICAL NOTES

3.1 Welding.

All welding must be of the highest quality possible, with full penetration.

All bars welded together must have the joint mating surfaces entirely welded.

Note.

NASA via a designated Scrutineer reserves the right to reject any welding that may be deemed insufficient and or incorrect.

- 3.2 All bolts, set screws and nuts used must be of steel and be of a minimum of R or S quality. Square headed bolts are prohibited.
- 3.3 All driver controls must be operated from, and remain within, the drivers compartment at all times.
- 3.4 The fitting and/or use of aerofoils, spoilers, wings, splitters, and/or any device to enhance vehicle adhesion to the ground via the airflow over or under the vehicle or device are prohibited.
The fitting of mascots, toys, banners, flags or ornamentation is prohibited.
- 3.5 There must be no sharp or protruding surfaces that may be regarded as a hazard, either internally or externally.
- 3.6. Traction/Launch Control (See definitions) systems, including start line driver aids prohibited.
Note.
Inspection/Retention/Sealing of control equipment as per General - rules 2.4 & 2.5 will apply.
- 3.7 Towing & Lifting Points.
The "Towing" and or "Lifting" points must be clearly marked.
A "Towing Eye"/"Lifting point eye" may be fitted. Towing Eyes" and "Towing Eye fixings" that are excessively sized or that can be regarded as 'ballast' or 'protection' are prohibited. Flexible/strap type towing eye permitted.

4. ENGINE SPECIFICATION.

- 4.1 See individual "Special" class rules.

5. ENGINE SEALING & CAPACITY LABELLING

5.1. Engine Sealing.

See individual "Special" class rules.

The engine must have provision for the fitting of at least one readily accessible scrutineers wire seal, such that the fitting of the wire seal prevents access to internal engine components.

A minimum of two adjacent engine cylinder head retaining studs or bolts must have a single 2mm (1/16") diameter hole pre-drilled in each of them.

- i. Where the method of cylinder head retention is by means of a stud and locking nut the hole must be located above a cylinder head retaining locknut but below the top surface of the stud. (See Fig. 31).
- ii. Where the method of cylinder head retention is by means of a bolt the hole must be located through two adjacent edges of the hexagon head of the bolt.
- iii. Where cylinder head retaining studs and bolts are inaccessible, then a single 2mm (1/16") diameter hole must be pre-drilled in two accessible parts or areas of the engine.

Component Sealing

See Rules 2.4 & 2.5.

5.2. Capacity Labelling.

See individual "Special" class rules.

6. ENGINE LOCATION

6.1 Engine Location – Restricted.

The engine (s) may be positioned & fitted anywhere within the chassis that is to the rear of the rear roll cage upright.

The engine must be within the chassis structure. i.e. there must be chassis space-frame structure steel tube bars to the front, both sides and rear of the engine and transmission units. See Fig 26a & 26b.

As a rule of thumb in the event of a potential roll over or side/rear impact the chassis structure must be such that it is struck initially. It also must contain the engine/gearbox unit within the chassis structure in the event of any mountings failure.

The only disapplication of this requirement is for existing pre-1st October 2015 constructed “front” engined vehicles that have been registered with NASA prior to January 2016 and fitted with a NASA authorised “Tag”. Any such vehicle may continue to race until further notice. Any such non-tagged “front” engined vehicles are prohibited.

- 6.2. An engine must not be located in the Driver’s Compartment or any part of the engine unit protrude into the area forward of the front face of the rear roll cage hoop uprights.
- 6.3. The engine must be shielded from the driver. See also SECTION 12 SAFETY SHIELDS & GUARDS.
The engine(s) location is/are free elsewhere in the vehicle; however it/they must be suitably encased within the chassis structure. i.e. there must be chassis space-frame structure steel tube bars to the front, both sides and rear of the engine and transmission units. (See Figs. 26a).
As a rule of thumb in the event of a potential roll over or side/rear impact the chassis structure must be such that it is struck initially. It also must contain the engine/gearbox unit within the chassis structure in the event of any mountings failure.
- 6.4. Engine Mountings/Cradle.
Engine Mountings/stabilisers free. However they must be sufficient for size and weight of engine and stress loadings involved.
Engine Cradle mountings and construction must be fit for purpose. Excessive construction is regarded as ballast/reinforcement and prohibited.

7 TRANSMISSION

- 7.1. Transmission and or gearbox type – Restricted.
Drive: rear wheel drive only. i.e. the vehicle drive must be effected by the two rear wheels only.
See individual “Special” class rules.
- 7.2. Transmission/Gearbox Mountings/Cradle.
Transmission/Gearbox Mountings/stabilisers free. However they must be sufficient for size and weight of transmission/gearbox and stress loadings involved.
Transmission/Gearbox Cradle mountings and construction must be fit for purpose. Excessive construction is regarded as ballast/reinforcement and prohibited.
- 7.3. Transmission/Gearbox Location – Restricted.
The transmission/Gearbox must be shielded from the driver. See also SECTION 12 SAFETY SHIELDS & GUARDS.
The transmission/Gearbox must be located to the rear of the rear roll cage uprights.
The transmission/Gearbox location must be suitably encased within the chassis structure. i.e. there must be chassis space-frame structure steel tube bars to the front, side and rear of the engine and transmission units. (See Figs. 26a).
The only disapplication of this requirement is for existing pre-1st October 2015 constructed “front” engined vehicles that have been registered with NASA prior to January 2016 and fitted with a NASA authorised “Tag”. Any such vehicle may continue to race until further notice.
- 7.4. Gear Lever.
A single gear lever or operating device must be fitted to control the operation of the transmission system “Gear change” mechanism.
- 7.5. Clutch Operation – Restricted.
A single clutch pedal must be fitted to control the operation of the ‘clutch mechanism or engaging’ drives to the transmission system mechanism of the engine.
Clutch type - See individual “Special” class rules.
- 7.6. Drive Shafts & Wheel Hubs.
See individual “Special” class rules.
Note.
Whilst racing, Drive Shafts and wheel hubs may be subject to severe shock and stress loading. The type, size and construction and fixings must be suitable and fit for purpose for the shock and stress loadings of the “Autograss racing environment”. This must be borne in mind during Drive shaft and wheel hub system choices.

NASA reserves the right via an appointed Official and or Scrutineer to reject a drive shaft system, deemed as not fit for purpose and unsuitable for the shock and stress loadings of the “Autograss racing environment”.
- 7.7. Differential Type.
See individual “Special” class rules.

8 VEHICLE DIMENSIONS AND WEIGHT.

- 8.1. Vehicle Dimensions and Weight – Restricted.
NASA reserves the right to amend and or revise the minimum and or maximum stated dimensions and weights at any time.

Length & Width.

Maximum overall length = 4.0 metres.
Maximum overall width = 2.0 metres.

Vehicle track – Restricted.

The distance between two wheels on one axle is free provided it remains within stated overall dimensions.

Wheelbase – Restricted.

Minimum - See individual "Special" class rules.

Maximum - Free provided the overall length remains within stated overall dimensions.

Limits of construction – Side of vehicle.

No form of construction shall, on each side of the vehicle, protrude beyond an imaginary line joining, in plan view (i.e. when viewed from above) the centre of that side front wheel tyre with the centre of that side rear wheel tyre. (See Fig. 29.).

Limit of Construction - Front of vehicle.

The front of the vehicle shall not extend further than 610mm (24") in front of the centre line of the front wheels. (See Rule 11.4.).

Vehicle Height.

Shall be not less than 1067mm (3' 6") (42"), measured vertically downwards from a point on the vehicle roof directly above the driver's head, to the ground when the driver is seated in his/her normal driving position for that vehicle. (See Fig.3).

Roof Plan Area.

The roll cage roof plan area is free but the roof width must be not less than a minimum of 508mm (20") when measured at the narrowest point. See Rule 10.9.

Where a roof is tapered, from the minimum of 508mm (20") to a greater measurement, the mean width will be used as a datum.

Front of Vehicle – Profile/Shape & Size.

The front panel and or chassis and or nose cone of a vehicle must present a straight and flat front not less than 300mm (12") wide and 208mm (8") high. The front must be either vertical or within 15 degrees to the vertical. See Fig. 33.

Curved, rounded, bowed, arched, convex or concave construction and panelling is prohibited.

Vehicle Weight – Restricted.

See individual "Special" class rules.

8.2 Roll Cage Head Clearance.

There must be a minimum of 75mm (3") distance and clearance between the top of the helmet of the seated driver and the bottom surface (underside) of the roll cage roof bars.

8.3 Roll Cage Hoop Location Limit.

The main (rear) roll cage hoop must not be more than 254mm (10") behind the driver's helmet, when the driver is normally seated.

8.4 The driver's compartment width – Restricted.

Minimum width 600mm.

Maximum width free provided it remains within stated overall dimensions.

Note.

Where the distance 'V' (See Fig.21) is less than 50mm then driver's compartment side protection MUST be fitted.

8.5 Driver Leg Clearance.

There must be a minimum of 50mm (2") clearance, when the driver's legs are drawn back into a crouch type position, between the driver's knees and any bar or cross-member across or joining the nearside and offside top chassis rails or the "Dashboard" assembly. i.e. Should a driver have to remove his feet from any foot pedal and/or draw any leg back, he/she is able to do so quickly, without the knees being trapped by any cross bar or "Dashboard". See Fig. 27b.

8.6 Driver Feet Clearance.

The front of a special must be a minimum of 230mm (9") from the driver's feet when any of the foot control pedals are fully depressed by either of the driver's feet.

8.7 Ballast - Restricted.

See individual "Special" class rules.

9 STEERING

- 9.1** It is a requirement that all vehicles are able to steer at all times. All-wheel and/or rear wheel steering prohibited. NASA reserves the right via an appointed Official and or Scrutineer to request that a competitor's vehicle undergoes a steering capability test.

Refusal to comply with a request to take part in a steering capability test will immediately deem the vehicle as being in contravention of the NASA vehicle construction rules and make the competitor concerned subject to disciplinary action.

- 9.2** The steering system & drive from the steering wheel to front wheels is free however it/they must be within the chassis structure. i.e. there must be chassis space-frame structure steel tube bars to the front, side and rear of the steering drive and rack.

Note.

"Steering arms" must be of metal.

Open "Chain and or gear drives" must be fitted with chain & sprocket / gear guards.

Steering wheel lock and or locking devices are not allowed.

The use of "Kart" and or "Bicycle" steering components is prohibited.

9.3 Steering Column.

Steering column must be of metal.

Steering column form and location free.

The steering column must be attached to:

A support bar or supporting steel tubing frame work of roll cage specification or a minimum of 20mm steel tubing which is attached to the front roll cage uprights, between each upright, across the front of the driver's compartment in the dashboard area. The support bars must not hinder driver or medical personnel access and egress to driver compartment.

Power Steering – Column mounted.

Steering column mounted power steering units must be fitted with padding for protection of driver legs.

The steering wheel height/angle adjustment bracket/lever must be securely fixed in its chosen height/angle location by welding or secondary fastening.

9.4 Steering Wheel.

A full circumference steering wheel must be used. Diameter Restricted – See individual "Special" class rules.

Also See Rule 15.1.

The steering wheel used must be fitted correctly. The fitting of a "reversed" or "upside down" (Steering wheel rotated 180 degrees front to back) steering wheel is prohibited.

Quick Release steering wheel boss permitted. The boss must be fitted below the steering wheel.

The steering wheel height/angle adjustment bracket/lever must be securely fixed in its chosen height/angle location by secondary fastening.

Steering wheel lock and or locking devices are not allowed.

Note.

It is the driver's responsibility to ensure that the steering wheel is secure at all times. Steering wheels may be subject to random spot checks of steering wheel fitment and or boss and or fixings whilst on the starting line.

9.5 Steering Wheel Mounted Controls. – Restricted.

See individual "Special" class rules.

10 CHASSIS and ROLL CAGE

Roll cage specifications stipulated within this rule book are the minimum acceptable. Members should take account of the condition, physical strength and style of the vehicle and fit additional bars to the safety roll cage and chassis to satisfy themselves in respect of the overall safety of the vehicle. NASA is not responsible for the failings of any roll cage and or chassis construction as a result of its lack of design strength or manufacturing integrity.

NASA reserves the right via a Scrutineer to reject a roll cage and or chassis or structure of any vehicle that is considered to be of unsuitable construction.

10.1 A Special must be built in a secure manner and be robust and sufficient to withstand race track conditions and a collision or roll-over.

During a race and or a collision or roll over a special may be subjected to severe stress loadings. This should always be borne in mind when designing and/or building a special.

10.2 The chassis construction is free but must be of a steel tubular (Round/circular and/or box section) space frame construction. The use of a full or part "Monocoque" construction chassis is not permitted.

The chassis must incorporate the roll cage and required bracing bars, upper and lower chassis rails and side cross brace construction as specified.

10.3 The chassis, including roll cage, side bar and brace bar tubing must not be used as a medium for the flow of liquids, oil, water, fuel, or the internal passage of fluid piping and or electrical wiring.

10.4 Roll Cage Structure.

The roll cage structure must comply with the NASA Design incorporating the statutory or mandatory bars of the specified material and wall thickness. See Fig 1 for roll cage design.

The basic purpose of a roll cage is to protect the driver if the car should overturn, or be involved in a serious accident. This purpose should always be borne in mind during roll cage construction.

The roll cage design including additional and or extra bars fitted to the roll cage and or vehicle structure, and component mounting bars must not impede driver access to or egress from the vehicle or access for marshals/medical personnel/assistance in the event of a roll over or on-track incident.

The roll cage must comply with NASA design. See Fig 1.

The main roll cage structure will comprise:

Two main hoops.

Roof centre bar, roof cross bar and roof side bars. (See rule 10.8 & 10.9).

Front Bracing bars (See rule 10.11).

Rear Bracing Bars (See rule 10.11).

Drivers compartment/Side chassis bars. (See Rules 10.12, 10.13 & 10.14).

Diagonal bars (See rule 10.10).

Material.

The main roll cage and main chassis structure must be constructed of either:

(a). Steel circular section tube with a minimum diameter of 32mm (1¼") and with a minimum wall thickness of 2.5mm.

Or

(b). Steel box section tube with a minimum size of 30mm x 30mm and with a minimum wall thickness of 3.0mm.

Or

(c). Steel box section tube with a minimum size of 25mm x 25mm and with a minimum wall thickness of 2.5mm.

Wall thickness tolerances

- i. Steel circular section tube: maximum tolerance = 0.2mm. I.e. the absolute minimum thickness at any point = 2.3mm.
- ii. Steel box section tube: 30mm maximum tolerance = 0.5mm. I.e. the absolute minimum thickness at any point = 2.5mm.
- iii. Steel box section tube: 25mm maximum tolerance = 0.2mm. I.e. the absolute minimum thickness at any point = 2.3mm.

Note.

- i. Each of the roll cage individual component bars must be of a single continuous length of tube. i.e. One length bar per part.
The forming of a length of tube from two or more lengths by welding and concealing the welded joints by grinding/smoothing is prohibited.
- ii. The use of "Galvanised" steel tube prohibited.
- iii. The roll cage main hoops must be symmetrical about the length-wise centre line of the vehicle (See Fig.1).
- iv. The rear roll cage hoop uprights must be Vertical +/-50mm (2") measured at the top of the hoop. (See Fig. 2).
- v. Additional bars to provide further protection - material steel only, may be fitted, size, wall thickness and design free.

Compliance Tagging.

All Roll Cages must be fitted with a "Material Compliance Tag" coloured Blue complete with an individual serial number marked upon it.

A vehicle is not permitted to take part in Autograss racing without a roll cage fitted "Material Compliant Tag".

Location of Main Hoop Regarding Driver's Head.

The rear hoop must be located such that the seated driver is at all times within the boundaries of the whole roll cage structure including chassis.

The underside of the top bars of the roll cage must be not less than **75mm (3")** above the helmet of the seated driver.

The rear hoop shall not be located at any point that is greater than a distance of **254mm (10")** to the rear of the driver's helmet, when the driver is seated.

10.5 Roof "X" Bars.

A roll cage roof must incorporate two diagonal cross (X) bars. One cross bar from the nearside corner to the front offside corner and one from the rear offside corner to the front nearside corner.

Each crossbar to be of a minimum size of 20mm x 20mm and with a minimum wall thickness of 2mm.

The underside of the roof "X" Bars must be not less than 75mm (3") above the helmet of the seated driver.

10.6 Roof Width – Restricted.

The roll cage roof width must be not less than 508mm (20") at any point. See Fig. 3.

A roll cage roof that has a width of 600mm (24") or greater must, have:

Either A centrally positioned bar fitted between the rear hoop and the front hoop in addition to the two diagonal cross (X) bars described in Rule 10.8.

Or Two diagonal cross (X) bars of roll cage material. One cross bar from the nearside corner to the front offside corner and one from the rear offside corner to the front nearside corner.

All bars to be of material as specified in Rule 10.4.

Note.

The box shape and or frame formed by the roll cage roof bars must be such that the driver's body, including torso is within the box and or frame perimeter when seen in plan view from above.

The underside of the roof "X" Bars and or centre bar must be not less than 75mm (3") above the helmet of the seated driver.

10.7 Rear Hoop Diagonal bar.

There must be a diagonal bar fitted to the rear roll cage hoop. The bar must be welded from the point of intersection of the upright with the top rear roll cage bar, to a point within 75mm (3") of the point of intersection of the upright with the bottom chassis rail (see Fig. 1.) or in accordance with the alternative drawing Fig. 8.

This bar to be of material as specified in Rule 10.4.

10.8 Roll Cage Hoop Brace Bars.a). Rear Hoop – Forward brace bar.

There must be two (2) rear hoop brace bars fitted (Welded), one (1) on each side of the vehicle main (rear) roll cage hoop in a forward direction to connect to a point on the drivers compartment side chassis, with distance "X" 100mm (4") minimum (See Figs.1 and 4).

The brace bars to be straight and of material as specified in Rule 10.4.

b). Rear Hoop - Rearward brace bar.

There must be two roll cage hoop brace bars, one on each side of the vehicle main (rear) roll cage hoop, in a rearward direction to connect to a point on the rear chassis of the vehicle and at an angle not exceeding 60 degrees to the horizontal.

The brace bars to be straight and of material as specified in Rule 10.4.

The brace bars must be fixed (Welded/bolted) from a point:

- i As near as possible to the top of the rear roll cage hoop.
- ii Within 100mm (4") of the junction point of the rear roll cage upright and the top rear roll cage bar, see Fig.1.

c). Front Upright – Forward brace bar.

There must be two (2) Front upright brace bars fitted (Welded), one (1) on each side of the vehicle front roll cage hoop in a forward direction to connect to a point on the drivers compartment side chassis that is adjacent to a front suspension mounting point. (See Fig.1.).

The brace bars to be straight and of material consisting of steel tube circular 25mm minimum outside diameter or box section 25mm x 25mm minimum, – All 2.5mm minimum thickness.

- 10.9 The front and rear roll cage uprights, on each side of the vehicle must be connected by the following bars each of which must individually be of one continuous length of tube.
- a) A steel upper chassis member/rail constructed of box section tubing, minimum size 20mm x 20mm (3/4" x 3/4") or circular section tube with a minimum diameter of 25mm(1") and with a minimum thickness of 2mm. (See Rule 10.4, 10.13 & 10.14).
The upper chassis member/rail must be fixed at a height such that there is a minimum clearance of 150mm (6") above the driver's elbow, when the driver's arms are placed by his/her side, to the top of the upper chassis rail. (See Fig. 3).
- b) A steel lower chassis member/rail constructed of material as specified in Rule 10.4.
The chassis floor must be of a width of 500mm or greater i.e. the mean "nearside" outside edge to "offside" outside edge width of the "Drivers Compartment" chassis rails must not be less than 500mm. See Rule 11.3 regarding panelling.
Note.
There must be a minimum of two lower chassis rails, one on each side (nearside and offside) of the vehicle and a rear and front and other appropriate cross joining bars to form a oblong or "ladder" type box shape constructed of material as specified.
- c) Steel side bar(s) located midway between the upper and lower chassis member/rails, constructed as specified in Rule 10.4 (See also Rule 10.15). (See Figs. 1, 9 & 27).
- 10.10 If the upper chassis member as described in rule 10.9 (a) is constructed of material specified in Rule 10.4 then One (1) side bar may be fitted. (See Fig. 1.).
- 10.11 If the upper chassis member as described in rule 10.9(a) is NOT constructed of material as specified in rule 10.4 then a minimum of Two (2) side bars MUST be fitted, constructed of material specified in rule 10.4 and, fixed a minimum of 100mm (4") apart, for the protection of the lower half of the driver's body. (See Fig. 1.).
- 10.12 The main upper and lower chassis rails, from the rear roll cage hoop upright to a "Front bulkhead structure" joining the upper and lower chassis rails both horizontally from nearside to offside and vertically (Forming a front square or oblong "Box") located forward of the foot control pedals, must be constructed of material as specified in Rule 10.4. If this front bulkhead "Box" structure is also the front of the vehicle then the size must be as Rule 8.1.
- 10.13 Side "X" Bars.
The section of the chassis construction from the front roll cage hoop upright to the front bulkhead structure must also incorporate two No. side diagonal cross or (X) bars. i.e. one cross bar from the upper chassis rail and roll cage hoop joining corner to the lower chassis rail and lower front bulkhead structure upright corner and one from the lower chassis rail and roll cage hoop joining corner to the upper chassis rail and upper front bulkhead structure upright corner. Each side cross bar to be of minimum size of 20mm x 20mm and with a minimum thickness of 2mm.
Note:
The above is a minimum requirement. Additional cross bars to form a "Double cross" or (XX) pattern providing a structure of equal strength to the above may be fitted.
- 10.14 Floor "X" Bars.
It is recommended that the section of the lower chassis construction from the rear roll cage hoop upright to a front suspension mounting point incorporates two No. floor diagonal cross or (X) bars. i.e. one cross bar from the nearside lower chassis rail and roll cage hoop joining corner to a offside lower chassis rail front suspension wishbone mounting point, and one from the offside lower chassis rail and lower roll cage hoop joining corner to a nearside lower chassis rail front suspension wishbone mounting point. Each floor cross bar to be of minimum size of 20mm x 20mm and with a minimum thickness of 2mm.
Note:
The above is a recommended minimum requirement. Additional cross bars to form a "Double cross" or (XX) pattern providing a structure of equal strength to the above may be fitted.
- 10.15 Nose Cone - Restricted.
A nose cone may be fitted forward of the front bulkhead structure. The nose cone must be constructed of box section tubing minimum size 20mm x 20mm (3/4" x 3/4"), maximum 25mm x 25mm or circular section tube with a minimum diameter of 25mm (1"), maximum 32mm, and with a minimum thickness of 2mm. The front of the nose cone shall not extend further than 600mm (24") beyond the centre line of the front wheels. See Rules 8.1 & 11.4.
Note.
The fitting of battery enclosure box/container within the nose cone is only permitted if the nose cone is constructed of:
Either Steel circular section tube with a minimum diameter of 32mm (1 1/4in) and with a minimum wall thickness of 2.5mm.
Or Steel box section tube with a minimum size of 25mm x 25mm and with a minimum wall thickness of 2.5mm.
For fuel tank/battery enclosure protection it must also be panelled with metal sheet 2mm minimum thickness.
It is recommended that there is a clearance of 50mm between a battery enclosure box/container and nose cone to allow for slight structure deformation in the event of a front impact.
- NB. For vehicles constructed after January 2017 the fitting of a "nose cone" is prohibited".**
Vehicles constructed prior to this date may retain the nose cone provided it is compliant with the above rule.

11 CHASSIS PANELS

- 11.1 Panels used to clad and or cover the chassis structure and roll cage must be of sheet metal only and must be secured by means of positive fixings (screws, rivets or bolts). An adhesive may be used in conjunction with the described positive fixings.

Panel material.

Panel material to be either Steel sheet or Non Ferrous metal/Aluminium sheet.

Panel minimum Thickness:

Steel sheet = 22 Gauge (0.71mm (0.028")).

Non Ferrous Metal or Aluminium Sheet = 1mm (0.40").

Panel maximum Thickness: All metals = 3mm

Note.

The use of multiple sheets to provide an overall thickness to the required size is prohibited.

Apertures and grilles.

Apertures and grilles etc. into or through any panelling, that allow the flow of air to radiators/coolers, engine or engine components and/or ancillaries may be fitted, provided the airflows through enclosed ducting, which is shielded, from the vehicle driver.

- 11.2. Removable, hinged and or opening access panels are permitted. However they must have secondary fastenings to keep them secure whilst racing. The use of bonnet pins with aluminium posts/pins, elasticised luggage straps, string, rope, wire, padlocks, or any fastening that requires the use of a tool to gain access is prohibited.

Note.

Failure to ensure that the opening panels remain closed during racing is a Black Flag (Race Disqualification) offence.

- 11.3 Chassis Floor.

The whole section of the chassis floor from the rear roll cage upright to the foremost point of the vehicle; must be completely panelled with steel sheet of a minimum thickness of 2mm. The steel sheet shall be fixed to the chassis by means of welding by 25mm "Spot" or "Stitch" or "Seam" welds around the edge of the panel such that a minimum of 50% of the total edge is welded.

It is permitted to fit a maximum of 6 No. "Air / "Cleaning / draining holes" into the chassis floor panelling, each hole diameter free up to a maximum of 50mm diameter. i.e. A maximum of 6 holes may be fitted, one of which shall be deemed as an inspection /measurement hole.

Floor mounted" components - Restricted

It is not permitted to fix components direct to the floor panelling. The seat, steering rack and or pedal box and or battery box must be fixed to the chassis framework only.

- 11.4 Chassis sides top and front.

The whole section of the chassis from the front roll cage upright (Windscreen) to the foremost point of the vehicle. i.e. sides, top and front, including the driver's foot/feet compartment, and nose cone must be completely panelled. (See 11.1).

Note.

The front panelling may be fitted such that there is a gap (Maximum 230mm (9")) between the inside of the panelling and the front surface of the chassis frame. This to act as a 'Crush Panel' in the event of a front impact. See Rule 8.11 & 8.12 for length restriction.

- 11.5 Front bulkhead.

A metal bulkhead may be fitted immediately forward of the foot pedals. This bulkhead may be either incorporated within the "Front bulkhead structure" as described in rule 10.12, provided it is immediately forward (Within 25mm) of the foot pedals. If not it must be a separate panel.

Note.

Where an electrical battery(s) is / are fitted forward of the foot pedals. There must be a metal bulkhead as described above fitted between the foot pedals and electrical battery(s). See Rule 11.1 for material specification.

- 11.6 Drivers Compartment.

The area between the main (rear) roll cage upright and the front roll cage upright, from the lower chassis member/rail to the upper chassis member/rail, must be completely panelled and covered with metal sheet. The metal sheet shall be.

Either Steel sheet 1mm (0.040") minimum thickness.

Or Aluminium sheet 2mm (0.080") minimum thickness.

Note: The use of multiple steel sheets to provide an overall thickness to the required size is prohibited.

See Rule 11.3 regarding floor panelling.

- 11.7 The driver's compartment access aperture(s) may have a non-metal, non flammable partial covering or "Side screen" or "Splash guard" for driver protection from ground/track debris, dust etc. It must be securely retained / fixed to the drivers compartment top chassis rail and roll cage uprights such that its removal can be easily facilitated without the use of a tool or knife.

All fixings must be readily accessible to facilitate its quick removal in the event of an emergency.

The side height above drivers' compartment top chassis rail free up to a maximum side height of just below the lowest or bottom surface of the particular driver's safety helmet.

Note.

Access to electrical isolator switch must be readily available at all times

- 11.8 Aperture Webbing /Meshed Net.

It is the responsibility of all competitors to ensure that their arms are restrained from extending outside of their vehicle in the event of an accident or roll. This must be done by the use of either a permitted restraint or window net or by their seating position within their car (see also Rule 2.8).

If the driver's seating position within the vehicle is such that there is a risk of their arms extending out of either side of the vehicle then a non-metal webbed/meshed net must be fitted to both nearside and offside driver's compartment access apertures.

If an arm restraint system is not used then a non-metal webbed/meshed net on both nearside and offside driver's compartment access aperture (Either wholly or partially), is mandatory and must be fitted. See Fig. 35.

If an arm restraint system is used then the driver's compartment access aperture(s) may also have a non-metal webbed/meshed net covering (Either wholly or partially).

Webbing/Mesh Type.

The aperture webbed/meshed net covering must be of a NASA permitted proprietary manufactured brand and or construction. Full metal tube support bar/border and "gate opening" types prohibited. It must be fixed by quick release clips as supplied by the window webbing/meshed net manufacturer or be retained/fixed by the use of "R" clips. ("Bolted with hinge" types prohibited.) or "Heavy duty" Velcro.

11.9 Roll Cage Roof.

The whole section of the roll cage from the rear roll cage hoop to the front roll cage hoop; from the offside front hoop-rear hoop bar to the nearside front-rear hoop must be completely panelled of material as specified in rule 11.1.

11.10 Rear Roll Cage Hoop – Panelling.

The area enclosed by the rear roll cage nearside and offside hoop uprights and top rear roll bar, from vehicle floor level to the vehicle roof level (i.e. from the bottom chassis to the top roll bar and nearside chassis and/or roll cage upright to offside chassis and/or roll cage upright) must be completely panelled of material as specified in rule 11.1. (See Fig. 20). The fitting of "Air holes" to, in or through the panelling is prohibited.

12 SAFETY SHIELDS and GUARDS

12.1 All vehicles must be fitted with a metal fire shield, which completely protects the driver from the engine unit. From the vehicle floor to the rear roll cage hoop for the complete width of the roll cage structure. i.e. from nearside roll cage upright to the offside roll cage upright; it must "fill" the whole area enclosed by the floor chassis bar, rear uprights and top roof bar. (See Fig.20).

The engine unit must not be visible from the driver's compartment.
The fitting of "Air holes" to, in or through the metal fire shield is prohibited.

Fire Shield material to be either Steel sheet or Non Ferrous metal/Aluminium sheet.

Minimum Thickness:

Steel sheet = 22 Gauge (0.71mm (0.028")).

Non Ferrous Metal or Aluminium Sheet = 1mm (0.40").

Maximum Thickness: All metal fire shields = 3mm.

12.2 Rear mounted transverse engines - Safety shields.

Where transverse mounted "Single" or "Twin" engine installation is used, then the following safety shields must be securely fitted.

i Fire Shield.

From the vehicle floor to a height equal to the top of surface of the engine or engines' "Rocker or cam cover" for the complete width of the roll cage structure. i.e. from nearside roll cage upright to the offside roll cage upright. (See Fig.25). The shield is to be constructed from either: Steel sheet: minimum 2mm thickness or Aluminium sheet: minimum 3mm thickness.

ii Flywheel safety shield.

Fitted to interrupt a direct line between the vehicle driver and engine or engines' flywheel(s). The shield(s) to be constructed from steel plate minimum 6mm (¼") thickness, 460mm (18") high, 100mm (4") width.

12.3 Chain Drive Enclosure.

All transmission/drive chains must be encased (See Fig.23) by a substantial material, minimum 2mm steel sheet or Aluminium sheet: minimum 3mm thickness to contain the chain in the event of a breakage. i.e. The chain must not be visible.

12.4 Sump Guard – Restricted.

A sump guard or under engine/gearbox shield may be fitted. However it must be of metal with a maximum thickness of 3mm.

Size: Width = Maximum - No wider than vehicle chassis rails.

Length = Maximum – From bottom of rear roll cage upright to rear most point of gearbox.

12.5 Fluid Pipes.

Oil, water and fuel pipes, when fitted inside the driver's compartment, must be secure, completely encased/covered in a suitable material and of one continuous length, from the point where they enter to the point it leaves the driver's compartment. The material must be of sufficient strength to act as a mechanical protection.

12.6 Oil Tanks.

All oil tanks (Including catch tanks and dry sump tanks) must be shielded from the driver in case of spillage in an accident.

12.7 Cooling Systems.

Radiators, expansion tanks, intercoolers or any other cooling system, must be completely shielded from the driver's compartment, and be as leak proof as possible.

12.8 Fuel Systems.

All fuel related components, including the fuel tank and or "Fuel cell" and "fill pipe and cap" must be completely shielded from the driver's compartment, and be as leak proof as possible.

12.9 Pulleys/Belts/Chains.

All external revolving pulleys/belt/gear/chain drives must be shielded. i.e. None must be visible when the vehicle is viewed in any plane.

- 12.10 Suspension Shield.
Shock absorbers, springs or coil/shock absorber or link bars/arm assemblies located adjacent to the driver's compartment must be shielded from the driver. The shield is to be made of either steel or aluminium sheeting a minimum of 2mm thickness.

13 PROTECTION

- 13.1 Front Protection.
Front protection bars and or bumper/tree/nerf bars are not permitted.
- 13.2 Rear Protection.
Rear protection bars and or bumper bars are permitted, however, they must not protrude beyond the centre of the wheels.
Materials to be used must be no greater than 1" (25mm) box or 1¼" tubular (32mm).
- 13.3 Side Protection.
Driver's compartment side protection is permitted.
i.e. protection for the area between the front and rear roll cage uprights. (See rules 13.4, 13.5, and 13.6).
See individual "Special" class rules for whether mandatory or recommended.
- 13.4 Side Protection Bars.
If fitted, they shall on each side of the vehicle have a mean ride height, which is to an imaginary line joining, in side elevation (i.e. when viewed from the side) the centre of the particular side front wheel with the centre of that side rear wheel. (See Fig. 10 - 13 & 30).
Side protection bars may be used as suspension mounting points.
- 13.5 If a vehicle has a driver's compartment with a width of less than 24" (600mm) (Measured at the top chassis rail, to the outside of the chassis rails between each side of the driver's compartment - distance 'U'), and/or with distance "V" (See Fig.21) less than 50mm, then side protection bars MUST be fitted. (See rule 3.8 & 13.6).
- 13.6 If a vehicle has a driver's compartment width of less than 24" (600mm) - distance "U", (measured to the outside of the chassis rails, on each side of the driver's compartment) and/or with distance "V" less than 50mm, AND is fitted with "Side pods" externally to the side of the driver's compartment, constructed of a tubular framework consisting of a minimum of 20mm box or 25mm circular steel, and projecting more than 150mm (6") at 90 degrees from the external panelled face of the driver's compartment, then side protection bars may also be fitted.
- 13.7 Local gearbox, engine ancillary, fuel or oil tank protection, and exhaust protection is permitted. Materials to be used must be no greater than 25mm box or 32mm (1¼") tubular steel.
- 13.8 Protection bar construction
All protection bar construction must be fit for purpose.
NASA reserves the right via a Scrutineer to reject a construction component choice due to size and ability to provide the necessary protection.
Multiple or excessively large or oversized or "Heavyweight" protection bars may be regarded as ballast/reinforcement and prohibited.

14 SUSPENSION

- 14.1 Suspension type is restricted.
See individual "Special" class rules.
A passive suspension system must be fitted. "Solid" suspension prohibited.
Any form of passive suspension may be used.
Active /Adaptive/ semi-Active Suspension prohibited.
Suspension components must be shielded from driver. See rule 12.10.
- 14.2 Front Suspension - Type Restricted.
See individual "Special" class rules.
- 14.3 Rear Suspension - Type Restricted.
See individual "Special" class rules.
- 14.4 Suspension mounting points.
Suspension mounting points must be built in a secure manner and be robust and sufficient to withstand race track conditions. See Rule 12.10.
Note.
Where suspension mounting or support bars are fixed to the chassis, the fixing points must have a clearance of not less than 100mm (4") distance from any seat or harness fixing point.
- 14.5 Suspension Components.
All suspension components must be fit for purpose.
Suspension "Arms" & Wheel Hubs.
Suspension arms and wheel hubs must be of metal.

Suspension Bushes/Bump Stops.
Type, material and size – free.

Suspension springs.
Suspension spring type, number and rating – free.

Rose Joints.

Rose Joints must be correct and fit for purpose. Type and size – free.
The use of “Half nuts” for rose joint locking purposes permitted.

- 14.6 Wheel Camber/Castor & Wheel Alignment (Toe in/out)
Wheel camber, castor and alignment (toe in/out) is free. (See Section 9 – Steering).

- 14.7 Dust/dirt covers.
Shock absorber, springs or coil/shock absorber assembly dust/dirt covers of proprietary manufacture only permitted.

15 WINDSCREEN/GLASS

- 15.1 Windscreen.
The aperture enclosed by the front roll cage hoop, above the upper main chassis that forms a “Windscreen” must have a covering over the full “Windscreen” aperture ONLY of steel weld mesh 1” x 1” (25mm x 25mm) made up of a minimum 12 gauge (0.104”) (2.64mm) diameter wire. The mesh must be securely fixed (nut & bolt/welded) to the vehicle.

Note:

There must be adequate clearance between the windscreen mesh and the steering wheel to prevent injury to the driver’s hands.

- 15.2 Windscreen Perspex.
Perspex/Lexan/Clear Polycarbonate may be fitted to the outside of the mesh on the front screen only, provided that there is a suitable aperture cut in front of the driver, in his/her line of vision. The aperture must be at least 100mm (4”) high, 300mm (12”) wide, or the equivalent area within a 300mm (12”) diameter.

- 15.3 All gauges/instruments fitted with a glass lens must have the lens covered with adhesive tape such that the lens pieces are retained in the event of breakage.

- 15.4 Mirrors – Restricted.
A rear view mirror may be fitted; number and type free however it/they must not be of glass. Any mirror must be securely fixed directly to the vehicle chassis. Fixings to panels only are prohibited.
There shall be no sharp or pointed edges that may cause potential injury to driver or marshals in the event of deformation or breakage. Over large or excessively sized mirrors are prohibited.
Mirror protrusion beyond/outside of, any of the driver’s compartment apertures shall be kept to a minimum.

16 SAFETY HARNESES

- 16.1 All vehicles must be fitted with a proprietary manufactured full harness seat belt to BSI standards and be adjustable so as to securely fit driver, with one quick release buckle, a crutch strap and a minimum of 5 point fixing. The use of a 6-point fixing harness is recommended.
The whole harness seat belt must be supplied by the manufacturer of that harness seat belt and be fitted in accordance with the manufacturer’s installation recommendations.
N.B. Inertia type harness seat belt prohibited.

Note.

The driver’s seat must have the correct “seat harness holes”, adjustable as necessary to enable the choice of harness to suit the stature of the driver to be correctly fitted.

Whilst racing, the safety harness may be subject to severe shock and stress loading. The type, size and construction and fixings must be suitable and fit for purpose for the shock and stress loadings of the “Autograss racing environment”. This must be borne in mind during safety harness choices.

NASA reserves the right via an appointed Official and or Scrutineer to reject a safety harness and fixings, deemed as not fit for purpose and unsuitable for the shock and stress loadings of the “Autograss racing environment”.

- 16.2 Shoulder Straps.
The shoulder straps of the harness seat belt must ideally pull back at an angle of between 45 degrees and straight back.
The shoulder straps of the harness seat belt should ideally pull back at an angle of between 45 degrees and straight back and be fixed to the vehicle safety roll cage and or floor chassis and or a safety harness fixing bar located between the two roll cage uprights.
The safety harness shoulder straps must not be supported by the driver’s seat associated shoulder/neck holes only.

The safety harness shoulder straps when the rear angle is less than or more than 45 degrees to the horizontal must have a shoulder strap guide/supporting/fixing bar that must be fitted either between the two roll cage uprights. (See Fig.19a, 19b, & 19c.).

It is recommended that a harness “Strap guide” be fitted to ensure that the harness remains in position in the event of a roll over.

Note.

The harness shoulder straps must be a tight and correct fit on top of and over the driver’s shoulders and elsewhere on the driver’s body. This is a requirement to securely contain the driver within the seat in the event of a roll over. Therefore the stature of the driver and or drivers for shared vehicles must be considered during harness and or mounting point choices.

NASA reserves the right via an appointed Official and or Scrutineer to reject a safety harness and its fixings, and or require adjustments to be made particularly if the harness straps remain a “loose” fit when tightened.

- 16.3 Harness “Extension”.
Proprietary manufactured Safety Harness “extension pieces” only are permitted. “Homemade” extensions, rope, wire, tie straps, chains etc. prohibited.

16.4 Harness Fixing & Mounting Points.

Harness fixings and mounting points must be in accordance with the harness manufacturer's recommendations and be sound and secure.

Note.

- i. Attachment bolts for seat belts/safety harness must be minimum 10mm (3/8") high tensile steel.
- ii. Safety harness fixings must be mounted onto the vehicle chassis.
- iii. Safety harness fixings must not be mounted on any vehicle panel or metal sheet including floor steel sheet.
- iv. Safety harness fixing & mounting points, due to the potential fire risk must not be within the vehicle engine compartment.
No part of the harness shall be adjacent to or pass alongside or above the engine or carburettors/fuel injection system or exhaust system.
- v. The lap belt should be fixed such that the side straps ideally "pull down" at an angle of 45 degrees
- vi. The crutch strap must be fixed to a seat mounting bar/cradle and or main chassis and be fixed such that the seat does not become subject to a stress/force load.

Whilst racing, the safety harness and fixings may be subject to severe shock and stress loading. The type, size and construction and fixings must be suitable and fit for purpose for the shock and stress loadings of the "Autograss racing environment". This must be borne in mind during safety harness and fixing choices.

NASA reserves the right via an appointed Official and or Scrutineer to reject a safety harness and fixings, deemed as not fit for purpose and unsuitable for the shock and stress loadings of the "Autograss racing environment".

17 SEAT

- 17.1 A proprietary manufactured "Car", "Racing" or "Competition" or "Motor sport" car driver's seat only must be used.

Note.

The seat must have the correct "Seat harness holes", adjustable as necessary to enable the choice of harness to suit the stature of the driver to be correctly fitted.

The seat head restraint/headrest must be an integral part of the driver's seat construction and be such that it provides a support for the driver's head, regardless of the stature of any driver and will prevent the driver's head from being violently jerked backwards during an impact thus reducing the potential risk of neck injuries.

Seat Fit.

The seat must be adjustable for driver stature fit, seat location and harness location to securely hold the driver in place and to ensure correct control of the vehicle regardless of the stature of any driver. The means of adjustment shall be by positive fixings.

Any cushion used must be securely fixed.

- 17.2
- Seat Installation.

The seat must be installed in accordance with the particular manufacturer's recommendations and instructions and be in good order and or condition and be free of damage.

Seat Mounting / Fixing.

The driver's seat or seat frame must be securely fixed (bolted/welded) to the vehicle chassis, back and front (See Fig. 14). Bolt size 8mm HT or greater. The seat, seat to seat frame or seat frame to vehicle support brackets must be of an appropriate size and located such that they cannot puncture or pass through the seat in the event of any impact.

The mounting or fixing of a seat directly to sheet metal only is prohibited.

Note.

Where a seat manufacturer recommends that base fixing only is required then additional fixings to the seat support bar are not required. (For such seats documentary evidence shall be provided by the competitor to the designated official upon request). However the support bar must be fitted.

Where a seat manufacturer's "mounting instructions" (e.g. Kirkey) does not recommend the use of "sliding seat fixings" and or "sliders" and or "seat adjustment" mechanism(s) then they are prohibited.

Seat Support Bars & Cradle.

A steel seat support bar must be fitted, minimum size 25mm circular or box section, with minimum wall thickness 2.5mm directly to the rear of the seat backrest. See Fig. 19. The back of the seat must be fixed (Bolted/welded) to the seat support bar in two (2) places by means of appropriate support bar brackets adjacent to the safety harness apertures. The drilling/cutting through of the support bar is prohibited.

If the seat is fitted directly to the rear roll cage hoop diagonal bar via steel fixings of sufficient size and strength, then the diagonal bar is deemed as equivalent to the support bar and an additional support bar is not required.

If the seat is not fitted directly to the rear roll cage hoop diagonal bar then a separate support bar is required.

The base of the seat must be fixed (Nut & Bolted/welded) to the mounting bars/cradle/ and vehicle chassis by means of a minimum of 4 fixings.

Whilst racing or in the event of an accident or roll over, the seat, seat frame, seat mounting brackets and fixings may be subject to severe shock and stress loading. The seat, seat frame, seat mounting brackets and fixings must be suitable and fit for purpose for the shock and stress loadings of the "Autograss racing environment". This must be borne in mind during seat and/or seat frame and mounting bracket choices.

- 17.3 The direct fixing of any non-cushion item including instruments, driver controls, battery, fuel tank and their associated support brackets/bars to a driver's seat is prohibited.

- 17.4 NASA reserves the right via an appointed Official and or Scrutineer to reject a seat (including mounting support frame/brackets), particularly "Thin", "Lightweight" or "Ultralight" types that are marketed as a "Race seat" but deemed as not fit for purpose and unsuitable for the shock and stress loadings of the 'Autograss racing environment'.

18 FIRE EXTINGUISHER

- 18.1 It is recommended that all competitors be in possession of a fire extinguisher which is in good working order. All competitors must have easy access to a fire extinguisher which is in good working order at all times, especially when refuelling.
A fire extinguisher may be carried in the vehicle during racing. If the extinguisher is fitted in the racing vehicle then it must be securely fixed and be within easy reach of the driver.
- 18.2 Extinguishers must be minimum 1 kg (2.2 lbs) dry powder or 0.9 litre foam spray AFFF or Zero 2000. The “use by” date must be current and the “stored pressure” indicator must be within the manufacturer’s recommended limits. For extinguishers subject to regular inspection and service, a current record of inspection/test must be shown. All inspection and servicing must be carried out by a “competent person” in accordance with BS 5306 (current edition).

19 VEHICLE IDENTIFICATION

- 19.1 All vehicles must have the competitor’s NASA registered/recognised Club letters and racing numbers, displayed (See Rule 8.5) on each side of the vehicle and on each side of a specified roof structure, at a point forward of the rear roll cage upright, to a minimum size of 230mm (9”) in height, with a minimum 25mm (1”) width. The Identification (Club letters & Racing number) must match that stated in the competitor’s NASA Licence. i.e. if AA123 in Licence then it is AA123 Not 123AA or A123A on vehicle. (See Fig. 15).
Note.
i. The purpose of the vehicle identification requirement is to ensure that race lap scorers and officials can easily and correctly view and identify each vehicle from their race observation locations during any race. This must be borne in mind during identification font sizing and layout choices.
ii. The Lap Scorers and or appointed Officials wish to correctly identify each vehicle that is racing and or on track and also record the race results. It must be borne in mind during identification choices that NASA shall not be held responsible for the erroneous recording and or omission of any vehicle, regarding race results due to indistinct, dirty and or illegible identification.
- 19.2 All NASA registered/recognised racing numbers, club letters and class numbers must be displayed the colour black on a white panel background. i.e. a background that is displayed/painted so as to be the colour white. Iridescent or chameleon effect (Colour Change) Letters or Numbers or panels prohibited.
- 19.3 All NASA registered/recognised racing numbers, club letters and class number font is free however they must be sized so as to be proportioned such that they are clear and legible, and upright.
i. There must be a minimum of 50mm– Side Identification, 5mm – Roof Identification, clearance between the outside border and/or edge of the letter and/or number characters, regardless of font, and the outside border and/or edge of the white panel background.
ii. There must be a minimum of 25mm between the club identification letters and race number grouping of characters. E.g. for AAC 123 there must be a minimum of 25mm between the character “C” and “1”.
iii. The shading, blocking, outlining, overlapping, use of disproportionate sizing and/or leaning at an angle other than vertical of the letters and numbers is prohibited. See Fig. 15.

Identification SizesVehicle Side.

A minimum size of 230mm (9”) in height, with a minimum 25mm (1”) width. (See Fig. 7).

Vehicle Roof.

A minimum size of 150mm (6”) in height, with a minimum 12mm (1/2”) width. (See Fig. 7).

Roof Display Structure – Restricted.

The stand up structure MUST be made of 0.71mm (0.028”) (22 gauge) aluminium, to the dimensions shown on Fig. 8. The length being discretionary within the vehicle roof area.

Note.

The roof display structure size must be appropriate for the size and type of font used.

NASA reserves the right via an appointed Official and or Scrutineer to reject identification deemed as not fit for purpose and unsuitable for official purposes.

- 19.4 Class Identification.
The vehicle must have the NASA registered/recognised racing class identification number displayed upon the vehicle roof over both the nearside and offside driver’s compartment access aperture to a maximum height of 50mm (2”), minimum 25mm (1”).
- 19.5 Vehicle Paint & Decoration.
Vehicle paint and decoration is free, however stickers, logos, decals, drawings, phrases etc., which may be considered, obscene, offensive or intimidating are prohibited.

20 ELECTRICAL & INSTRUMENTS

- 20.1 Wiring Harness & Charging system.
The general wiring harness and charging system is free.
- 20.2 Ignition Switch.
A single ignition switch of proprietary manufacture must be fitted to control the ignition system to the engine or engines. The use of “Sub-ignition switches” to independently control the ignition system to each engine in twin-engine installations is prohibited.

Ignition Switch Location – Restricted.

The ignition switch must be within reach of the vehicle driver when the driver is seated in the vehicle seat and in his/her normal driving position, with his/her safety harness fastened.

20.3 Battery Isolator.

A single electrical system & battery isolator switch of proprietary manufacture must be fitted in either the Positive (+) or Negative (-) electrical "Live" or "Earth" circuit.

On operation of the battery isolator switch, the vehicle electrical system and engine must stop.

20.4 Battery Isolator Location – Restricted.

The battery isolator on/off switch must be fitted on the offside of the vehicle, at the base of the front roll cage hoop, adjacent to the point where it meets the top chassis rail. The switch "On/Off" positions must be clearly identified & displayed/painted a minimum size of 25mm (1") in height. (See Fig.17).

20.5 Battery Size and number off – Restricted.

See individual "Special" class rules.

20.6 Battery Enclosure & location – Restricted.

A battery must be secured within a metal enclosure box/container of sufficient strength not to burst open upon any impact and that is made as leak-proof as possible.

The enclosure box/container maximum size = 300mm Height x 300mm Width x 600mm Length.

Maximum wall thickness = 3mm.

The enclosure box/container must be located within the bounds of the vehicle chassis.

The enclosure box/container must be firmly secured to the vehicle.

See individual "Special" class rules.

Drivers Compartment.

The fitting of an electrical battery enclosure/box/container within the driver's compartment is permitted. However the battery enclosure/box/container must not be fitted beneath the driver's seat.

Limit of location – Vehicle Front.

The enclosure box/container must not be fitted anywhere on the vehicle at a point that is forward of an imaginary line, across the vehicle from the most forward part of the front suspension mounting points.

20.7 Instrumentation & Gauges- Restricted.

All instrumentation and gauges must be securely fixed to the vehicle.

See individual "Special" class rules.

Note.

Inspection/Retention/Sealing of instrumentation/control equipment as per General - rules 2.4 & 2.5 will apply in all classes.

20.8 Electrical Fuel Delivery Pump.

For a vehicle fitted with an electrical fuel delivery pump the fuel pump electrical connection must be wired through the main ignition switch.

20.9 Engine Starter System.

All vehicles must be fitted with a self-starting system capable of starting the engine when operated.

20.10 Ignition Leads & Spark Plugs.

Ignition leads and spark plugs type is free.

20.11 Brake Light.

A minimum of One (1) number Brake light, of 21 watts output and lens size 70mm x 70mm must be fitted to all vehicles.

The mandatory brake light to be mounted facing rearwards (Towards an imaginary marshal standing at the vehicle rear) at a point as near to the rear most point of the vehicle as practicable.

Secondary Brake Light.

It is permitted to fit a secondary brake light, mounted onto the offside roll cage upright facing outwards (Towards an imaginary marshal standing at the vehicle side). All brake lights must be covered with a red plastic lens and be clearly visible when in operation. "LED" lamps that emit a light that is the colour red of a minimum size 50mm x 50mm and that is clearly visible when in operation are permitted.

21 FUEL

21.1 Pump fuel only to be used.

Proprietary manufactured petrol Lead & Octane Replacement and Anti-Wear Additives may be used.

Note.

Fuel Additives are permitted. However their use must be in compliance with the particular manufacturer's recommendations and instructions.

NASA reserves the right via an appointed Official and or Scrutineer to reject and or prohibit a fuel additive type at any time.

21.2 Nitrous Oxide (N₂O).

The use of Nitrous Oxide (N₂O) injection is prohibited.

21.3 Carburetion and or Fuel Injection permitted.

See individual "Special" class rules.

Note.

Where carburettors and or injection systems do not have positive fixings to attach them to a manifold or engine (i.e. nuts/bolts), then a steel wire tether must be fitted to retain them in the event of an accident or roll over.

- 21.4 Acceleration.
A single “Accelerator” or “Throttle” pedal, must be fitted to control the operation of the fuel delivery system to the engine or engines.
The use of “Sub-pedals or devices” to independently control the fuel delivery to each engine in twin-engine installations is prohibited.
All engines must be fitted with an “Accelerator” or “Throttle” return spring of sufficient size, strength and movement such that the fuel delivery system closes once the “Accelerator” or “Throttle” pedal is released.
Note.
The accelerator/throttle cable/connection system must be sufficiently routed, shielded/protected from any heat source, and lubricated to minimise the risk of seizure/failure.
- 21.5 Fuel pump and Fuel regulator – Restricted.
See individual “Special” class rules.
- 21.6 Fuel Filter – Restricted.
See individual “Special” class rules.
- 21.7 Fuel Tank Type - Restricted
A single non-spill proprietary metal fuel tank or NASA permitted proprietary “Fuel cell”, with a maximum capacity of 10 Litres (2. Gallons) and that has a secure screw filler cap must be fitted.
Fixings:
For a metal fuel tank the fixings must be such that the tank and fill pipe and cap are secure. The use of non-metal fixing straps, wire, etc is prohibited.
Note.
For a “Fuel cell” the original fuel cell manufacturers “Fixing kit” only must be used and the “Fuel cell” must be secure.
- 21.8 Fuel Tank – Location – Restricted.
The fuel tank fuel tank and or “Fuel cell” must be fitted to the rear of the rear face of the rear roll cage hoop uprights.
See Rules 21.15 & 21.16.
- 21.9 Fuel tank Venting.
The fuel tank and or “Fuel cell” must have an external vent pipe fastened in a downward position, to a point below the floor of the car. This vent pipe must not protrude into the fuel tank or “Fuel cell” more than 6mm (1/4”). It is also recommended that a one-way (non return) valve be fitted in the vent pipe.
Note.
Where a “Fuel cell” is used the vent pipe must be connected to the fuel cell by proprietary fittings and in a manner approved by the fuel cell manufacturer.
- 21.10 Fuel Tank Fill pipe.
The fuel fill pipe must be fitted so as to be an integral part of the fuel tank or “Fuel cell”.
Where a fuel filler pipe and or filler cap is located beneath or under a vehicle panel there must be clearance above the filler pipe and or cap to allow for deformation in the event of a roll over.
- 21.11 Fuel Tank Outlet.
The fuel tank and or “Fuel cell” outlet delivery pipe must be fitted so as to be an integral part of the fuel tank or “Fuel cell”.
- 21.12 Fuel Tap.
A fuel tank and or “Fuel cell” outlet fuel delivery “Fuel shut –off” tap may be fitted. However it must be fitted so as to be an integral part of the fuel tank or “Fuel cell”. “In line” fuel taps prohibited.
- 21.13 Fuel Delivery Pipe
Fuel delivery pipes must be of metal or proprietary fuel flexible hose and be securely fixed. Fuel pipe fittings must be of proprietary manufacture.
Note:
Where a “Fuel cell” is used the fuel delivery pipes must be connected to the fuel cell by proprietary fittings and in a manner approved by the fuel cell manufacturer.
- 21.14 Fuel Tank Enclosure
If the fuel tank or “Fuel cell” is fitted within a totally enclosed space, a 50mm diameter hole MUST be provided as near to the tank as possible in one accessible face of the enclosure. This is for accessibility of a fire extinguisher nozzle in the event of fire.
- 21.15 Fuel System Protection.
If a fuel tank or “Fuel cell” or carburettor or fuel injection is fitted at the rear of a special, then depending upon the location of the fuel tank or “Fuel cell” or carburettor or fuel injection, protection will be required. (See Rule 21.16).
- 21.16 Fuel Tank/Fuel Cell/Carburettor/Fuel Injection/Air Filter Protection.
Where an Fuel Tank/Fuel Cell/Carburettor/Fuel Injection/Air Filter is fitted at the rear of a special and protrudes beyond the line of the rear brace bars and/or the rear chassis bars, then, for the safety and protection of the driver and marshals in the event of a roll over or rear impact, there MUST be at least one Fuel Tank/Fuel Cell/Carburettor/Fuel Injection/Air Filter protection bar for each Fuel Tank/Fuel Cell/Carburettor/Fuel Injection Unit/Air Filter consisting of a minimum of 20mm box or 25mm circular section steel tube.

22 COOLING SYSTEMS**22.1 Radiators & Coolers.**

Oil coolers are permitted.

Note.

Location restricted. They must be fitted to the rear of the rear roll cage upright and be within the chassis structure. It (they) must be to the rear of the rear face of the rear roll cage upright, and be below the top face of the rear brace bars and be within the shaded area shown on Fig.18. See Rule 22.8.

22.2 Cooling System Shields.

Radiators, coolers/intercoolers, expansion tanks, oil tanks, catch tanks or any other cooling system, must be completely shielded from the driver's compartment, and be as leak proof as possible.

22.3 Water Pressure Cap.

Water radiator(s) or header tank(s) must be fitted with a pressure cap. There must be an overflow pipe fitted, fastened in a downward position to terminate at a point below the vehicle chassis floor.

22.4 Water & Coolant Pipes.

Water and coolant pipes/hoses must be of metal or proprietary flexible hose. Type free. Silicone hoses permitted.

22.5 Oil Pipes/Hoses.

Oil pipes/hoses must be of the correct oil resistant type with suitable high-pressure oil connections/fittings.

22.6 Oil Tank location – Restricted.

Oil tanks (Including breather catch tanks and dry sump tanks) must be fitted to the rear of the front roll cage upright. It is recommended that they be fitted to the rear of the rear roll cage upright.

Oil tanks (Including breather catch tanks and dry sump tanks) must be shielded from the driver in case of spillage in an accident.

If an oil tank is fitted at the rear of a special, then depending upon the oil tank's location, protection will be required. (See PROTECTION - Rule 13.7).

22.7 Air Scoops.

Where a radiator-cooling air-inlet scoop is fitted at vehicle roof level it must not protrude above the vehicle roof by more than 75mm (3") and be no wider than 450mm (18").

22.8 Radiator/cooler Protection.

Radiators, coolers and or intercoolers fitted at the rear of specials must also have radiator protection bars fitted. Rear brace bars may suffice as protection bars if and or where they are above the radiator/cooler.

Where radiators, coolers and or intercoolers are fitted to the rear of the rear brace bars it (they) must be within the shaded area as shown on Fig.18. and be fitted such that they are with 1metre (33") of the ground when vehicle at standstill. If it (they) protrudes either beyond the rear brace bars or main chassis, for safety and protection of following competitors, the radiators/coolers must be adequately protected, with a framework consisting of a minimum of 1" (25mm) box or 1¼" (32mm) circular/tubular. (See Fig.18).

22.9 Oil Tank Protection.

Where an Oil Tank is fitted at the rear of a special and protrudes beyond the line of the rear brace bars and/or the rear chassis bars, then, for the safety and protection of the driver and marshals in the event of a roll over or rear impact, there MUST be at least one Oil Tank protection bar for each Oil Tank consisting of a minimum of 20mm box or 25mm circular section steel tube. (See PROTECTION - Rule 13.7).

23 BRAKES**23.1 Vehicle braking system.**

A braking system must be fitted, be correctly installed/fitted and be in good working order.

All wheels must "Lock" on grass on application of the foot brake pedal only at all times.

Brakes may be subject to random spot checks of foot pedal operation whilst on the starting line.

Note.

i. The original standard production brake pipes and hoses may be replaced with aftermarket "Braided" brake hoses.

ii. Anti-lock and/or ABS braking systems prohibited.

iii. The practice of adjustment of drum brakes shoes to an absolute minimum setting, regardless of shoe thickness, to reduce friction is prohibited.

Brake shoes must be fitted and adjusted such that they operate correctly upon the brake drum on the initial depression of the foot brake pedal at all times.

Note:

Whilst racing the braking system may be subject to severe stress, pressure and/or heat loading and or bombardment by debris from the unsealed track surface. This must be borne in mind during brake and brake component choices.

NASA reserves the right via a Scrutineer to reject a component choice due to size and ability and or capacity to provide the necessary braking force.

See individual "Special" class rules.

23.2 A brake device (Calliper & disc or shoe & drum) must be fitted on each wheel hub and or wheel hub drive shaft and be kept in good working order at all times.

Brake pads/Shoe lining type = free.

Note. The use of "Kart" and or "Bicycle" brake disc and or brake calliper is prohibited.

23.3 The brake device fitted on each axle hub or wheel hub drive shaft of an axle must be equal in type, size and capacity.

i.e. If a disc and calliper is fitted to nearside rear hub, or nearside driveshaft then a disc and calliper of equal size and capacity must be fitted on the offside rear hub or offside drive shaft

- 23.4 A single foot brake pedal must be used to operate the braking system master cylinder.
Pedal foot pad number - Minimum = 1. Maximum = 2.
- 23.5 Handbrake.
A handbrake/parking brake may be fitted. If fitted a handbrake/parking brake must operate the rear wheel braking system only. Hydraulic handbrake permitted. Electric/electronic handbrake/parking brake prohibited..
- 23.6 Braking System Usage.
All drivers must have the capability to operate the braking system correctly.
NASA reserves the right via an appointed Official and or Scrutineer to prevent a vehicle from racing due to the observed failure of a competitor to operate the vehicle braking system satisfactorily.
- 23.7 Brake proportioning - Restricted.
The fitting and use of a brake system proportioning “Brake Balance Bar” and or brake proportioning valve and associated adjustment mechanisms (including lever or knob) is permitted.
The fitting of a brake fluid shut off or isolation tap to facilitate the isolation or deactivation of any part of the braking system is prohibited.
- 23.8 Brake Pipework.
Brake fluid pipes and hoses of proprietary manufacture only permitted. Braided brake hose permitted.
Note. Whilst racing the braking system pipework may be subject to bombardment by debris from the unsealed track surface and or other vehicles.

It is recommended that the pipework to a wheel hub brake drum or disc calliper must be mounted on the rearward face of a suspension wishbone or suspension/hub mounting arm such that it is not in a direct line of assault from track surface debris.
If this is not possible then it is recommended that a formed metal shield barrier with a minimum thickness of 2mm must be fitted to protect the pipework.
- 23.9 Brake Warning Light.
A Brake Warning Light must be fitted, and work correctly and be activated by the depression of the foot brake pedal only – See Rule 20.11.

24 WHEELS

- 24.1 A special must have 4 wheels only.
- 24.2 Type, width and diameter of road wheel is restricted.
See individual “Special” class rules.
All wheels must be in good order and or condition and be free of damage. Steel or alloy wheels are permitted.
- i. Modification of a proprietary manufactured wheel Modification of a proprietary manufactured wheel by “Thinning” and or “Diameter reduction” and or “Grooving”, “Slotting” or “Drilling” and or other machining is prohibited.
 - ii. A wheel must of a suitable size sufficient for the tyre fitted.
 - iii. The use of different wheel diameter sizes on the offside and nearside of the vehicle is prohibited.
 - iv. The use of hub caps and or dust/mud shield and any attachments prohibited.
 - v. Wheels must have a single tyre inflation valve orifice in its standard production location.
 - vi. Wire wheels and/or “Twin wheels” are prohibited.
- 24.3 Wheel fixings – Type Restricted.
- i. Wheel centres must only be fitted to hubs the correct way.
 - ii. Wheel studs and nut fixings only permitted.
 - iii. The wheel nut must be completely penetrated and threaded by the wheel stud.
 - iv. The correct number and size of studs and nuts must be fitted for all the wheels used. Wheel nuts must be used to match the nut taper and stud bore and depth of the particular wheel (Including spacer if used) concerned. The studs/nuts must not protrude beyond wheel rim.
 - v. Locking wheel nuts/bolts prohibited.
 - vi. All studs must be of a one-piece type.
 - vii. Single nut and/or stud and/or centre lock wheel fixings prohibited.
 - viii. “Half nuts” and/or “Alloy” or non-steel nuts prohibited.
 - ix. “Plated” wheel studs prohibited.
- 24.4 Wheel Spacers – Type restricted.
See individual “Special” class rules for size restriction.
- i. The fitting of wheel spacers is permitted.
 - ii. A wheel spacer must be of proprietary manufacture, be of solid one piece that incorporates an integral backing plate.
Note. The hollow type spacers and or those requiring “Extension studs” are prohibited.
 - iii. The alteration of or thinning or machining of proprietary wheel spacers is prohibited.
 - iv. The spacer must be of uniform width and diameter.
 - v. The associated wheel studs must be of a one-piece type and of correct size. “Extension studs” prohibited
- 24.5 Wheel Adaptors. – Type restricted.
The use of wheel adaptors to fit wheels of a different PCD is permitted.
The use of wheel spacers and/or combined wheel spacer and wheel adapter permitted.
Note.
Whilst racing, a wheel adaptor/spacer may be subject to severe shock and stress loading. Adaptor/spacer type and construction and fixings must be suitable and fit for purpose for the shock and stress loadings of the “Autograss racing environment”. This must be borne in mind during adaptor/spacer choices.

NASA reserves the right via an appointed Official and or Scrutineer to reject an adaptor/spacer, deemed as not fit for purpose and unsuitable for the shock and stress loadings of the “Autograss racing environment”.

25 TYRES

25.1 Tyres are restricted.

For “drive axles” and/or “drive wheels” Control Tyres will apply.
The application of Control Tyres will remain effective until 31 December 2021.
NASA reserves the right to modify these regulations without notice at any time.

All tyres used on drive wheels have to be tested and agreed by NASA prior to use, permitted tyres will be listed under option A or option B on the NASA permitted tyre list.

Tyre Options.

There are 3 options. “A” and “B” and “Wet Weather”.

A competitor may use tyres on that comply with either option on a “Drive axle”. Mixing & matching of Option “A” and Option “B” and or “Wet Weather” tyres on the same axle is permitted.

- i. All tyre identification markings must be present and visible on each of the tyre sidewalls.
Removal of identification markings is not permitted.
- ii. The shore hardness value must be marked upon all Option “A” tyres.
This marking is to be clearly visible, non removable and applied during the tyre manufacturing process.
(‘Sticky labels’ applied by the retailer or “Branding iron” markings are not permitted).
Tyres that are not marked with shore hardness value during manufacturing will be deemed as Option “B” Tyres and then must comply with Option “B” regulations.
- iii. The tread block/pattern/profile must be pre-formed and made during the original manufacturing process.

Note.

Alteration or modification to original manufacturer’s tread pattern by “Tyre cutting” is not allowed.

- iv. All tyres whether Control Tyres or other, must have a speed rating of a minimum of 75 mph (“L” speed symbol).
“M & S” (Mud & Snow) tyres are permitted subject to drive & non drive axles and Control Tyre restrictions. Motorcycle tyres prohibited.
- v. Tyre Hardness - Restricted.
Tyre hardness must comply with the following. Random checks of hardness will be carried out by means of a Durometer. The checks will be carried out by authorised NASA officials. Tyres may be checked at any time.
Tyre manufacturers may incorporate a test block into the tyre tread pattern during the manufacturing process; otherwise readings will be taken from the most suitable tread block available.
For non control tyres (non drive wheels) the shore hardness is free.

Note.

- i. Control Tyres Option “A” and Option “B” must have absolute minimum shore hardness of 60 when the tyre is “new” or in “new condition”.
- ii. When tyres are tested/checked in any other circumstances the minimum shore hardness is 55, this to allow for tyre condition and or temperature. No tyre should ever measure less than 55 shore hardness.
- iii. If an Option “A” and or Option “B” tyre is measured/tested/checked and found to be below the stated minimum limit, the driver of the vehicle concerned will be subject to disciplinary action.
- vi. Tyre Fitment.
All tyres must be fitted to the wheel correctly and be in good condition. i.e. Be within wheel rim and or be free of damage to main tread pattern and sidewalls, including cuts, bulges, tears, rips, loose and or separated tread.

25.2 Tyre Option Description.

It is the responsibility of the competitor to ensure his/her Option “A” and Option “B” tyres comply with the NASA minimum shore hardness requirements

Option “A” Tyres

Tyres must be of a type supplied by a manufacturer/supplier as shown on the NASA permitted list of suppliers only. (The NASA supplier list is currently being updated).

Note. The tyre tread pattern and shore hardness must be of a type as permitted by NASA and subject to random testing as described in rule 14.1.

Option “B” Tyres.

Tyres must be an “E” marked Car road going “New” or “Remould” tyres that are permitted in law for road use only. The tyres must be available from any regular UK tyre distributor. The tyres must have a shore hardness rating of a minimum of 60 shore.

The cost of the tyre must be such that it has, or has had an initial sales value inclusive of VAT of less than £50.

NASA will maintain a register of approved Option B tyre makes/patterns. Tyres not on the NASA register are prohibited.

Wet Weather Tyres - Restricted.

Wet Weather tyres will be listed separately by NASA and are exempt from shore hardness controls.

Wet weather tyres must be as listed by NASA for wet weather use only.

Wet Weather tyres may be fitted to any axle/wheel.

Wet Weather tyres must also comply with NASA eligibility requirements – See rule 25.3.

25.3 Eligibility

- a). When a tyre is inspected and is not to the satisfaction of the authorised NASA official then it is deemed as being in contravention of the NASA vehicle construction rules and will not be eligible for use.
- b). It is Competitors responsibility to contact a scrutineer and or authorised NASA official to confirm that tyres are eligible **before** use.
- c). Tyres tread patterns must be only as permitted by NASA. Tyre tread patterns will be subject to regular review by NASA to ensure suitability for Autograss racing. NASA reserves the right to amend the permitted tyre tread pattern requirements at any time.

- d). NASA will invite tyre suppliers to a tyre meeting during each racing season to discuss the next year tyre requirements and or any concerns.

25.4 Tyre Width – Restricted.

The maximum permitted tyre width is 225.

See individual class specific rules for particular class tyre width and size restrictions.

25.5 Tyre Inner Tubes.

Tyres may be fitted with inner tubes. The placing of liquid into a tyre or inner tube is prohibited.

25.6 Tyre Performance Enhancement.

The use of any substance to change, enhance or improve the adhesion and/or softness & hardness properties of tyres is prohibited.

26 EXHAUST & SILENCING

26.1 Exhaust systems - See individual “Special” class rules for permitted systems.

26.2 All vehicles must be fitted with an efficient silencer capable of reducing the noise level to within the NASA specified noise limit 102 Db (A). For method of noise level measurement see SILENCING.

a). It is the competitor’s responsibility to:

- i). Ensure that his/her vehicle complies with sound testing regulations and it is recommended that competitors make themselves aware of any additional regulations imposed by clubs which they may visit before attending.
- ii). Ensure that his/her vehicle is constructed such that noise testing may be readily and easily carried out.
- iii). Familiarise themselves with the NASA Noise Test Chart showing the different engine r.p.m. test levels for different types of engines.

b). Test Engine RPM

The noise test engine r.p.m. shall be notified by NASA to each affiliated club’s Chief Scrutineer by means of a list showing the different levels for different types of engines cc. NASA reserves the right to amend and or revise the engine test r.p.m. at any time.

Note.

- i. A vehicle considered noisy by any official during racing may be disqualified notwithstanding that they may have passed the initial static test.
- ii Where a silencer’s performance is found to be insufficient to comply with the above, the use of any temporary modifications, including inserting drink’s cans, extra wire wool etc., into the silencer outlet pipe etc; is prohibited.
- iii. For further detailed information see also Members Handbook – SECTION – SILENCING.

26.3 All engine exhaust system pipe work forward of the rear roll cage upright must be contained within a fully panelled area or compartment of the vehicle chassis.

26.4 An exhaust pipe, fitted inside or protruding into the driver’s compartment, must be shielded from the driver.

Shield material to be either Steel sheet or Non Ferrous metal/Aluminium sheet.

Minimum Thickness: Steel sheet = 22 Gauge (0.71mm (0.028”).

Non Ferrous Metal or Aluminium Sheet = 1mm (0.40”).

Maximum Thickness: All metals = 3mm.

26.5 Exhaust Pipe Location.

Exhaust pipes must not protrude beyond the shaded area shown in Fig.22. The outlet pipe must be either horizontal or downward at an angle of not more than 30 degrees from the horizontal.

26.6 The single engine and/or twin engine exhaust system outlet or outlets must end at a point to the rear of the rear roll cage upright. This must be at a point height of not more than 838mm (33”) from ground level, and at a point that is easily accessible for the taking of noise level test measurement readings.

26.7 Exhaust Outlet Location.

All outlets of twin or multiple exhaust systems must terminate at a single common point enclosed within an imaginary area of 300mm diameter. (See Fig. 24.).

26.8 Any device(s) that acts as a valve and or regulator, whether adjustable or not, upon the exhaust gas flow within the exhaust system is/are prohibited.

27 BALLAST

27.1 See individual “Special” class rules.

The use of certain commercial vehicle and or agricultural vehicle and/or over large and or high wall thickness metal components may be construed as not permitted ballast and thus prohibited. Their use is not recommended.

28 CHECK SHEETS.

28.1 See individual “Special” class rules.

FIGURES.

FIGURE 1a. Roll Cage.

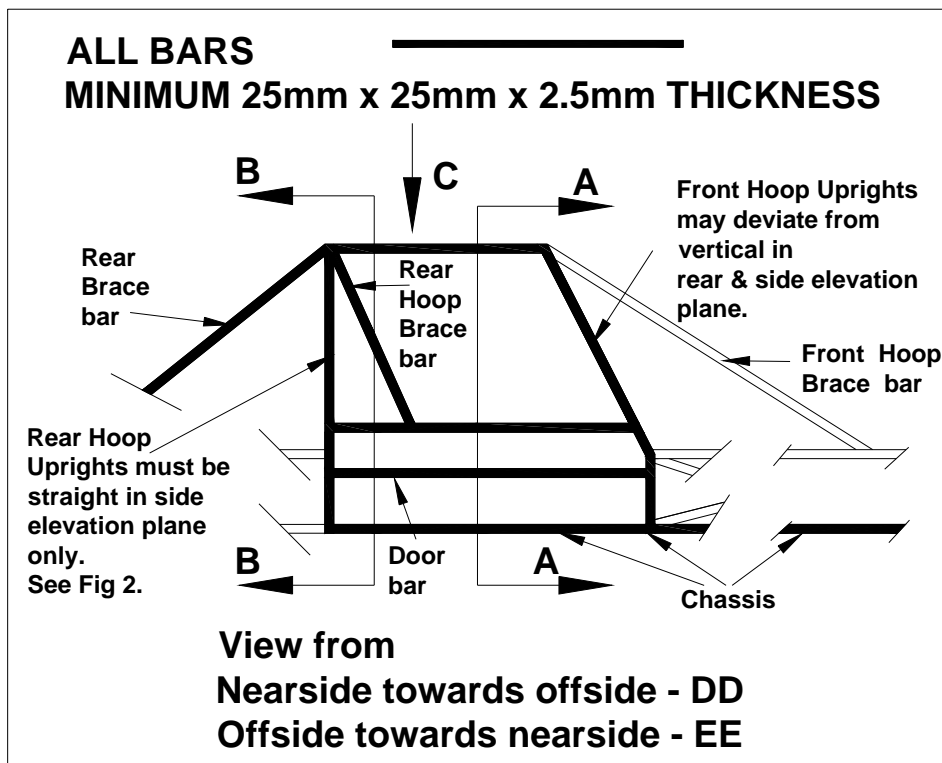

GJJ

FIGURE 1b. Roll Cage.

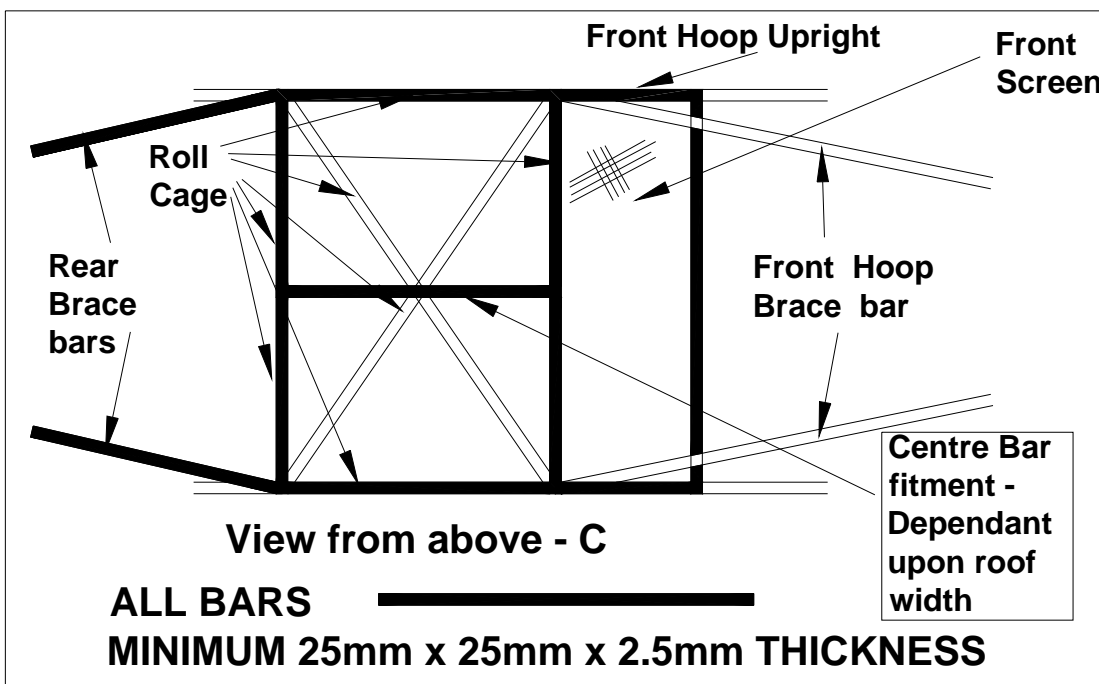

FIGURE 1c. Roll Cage.

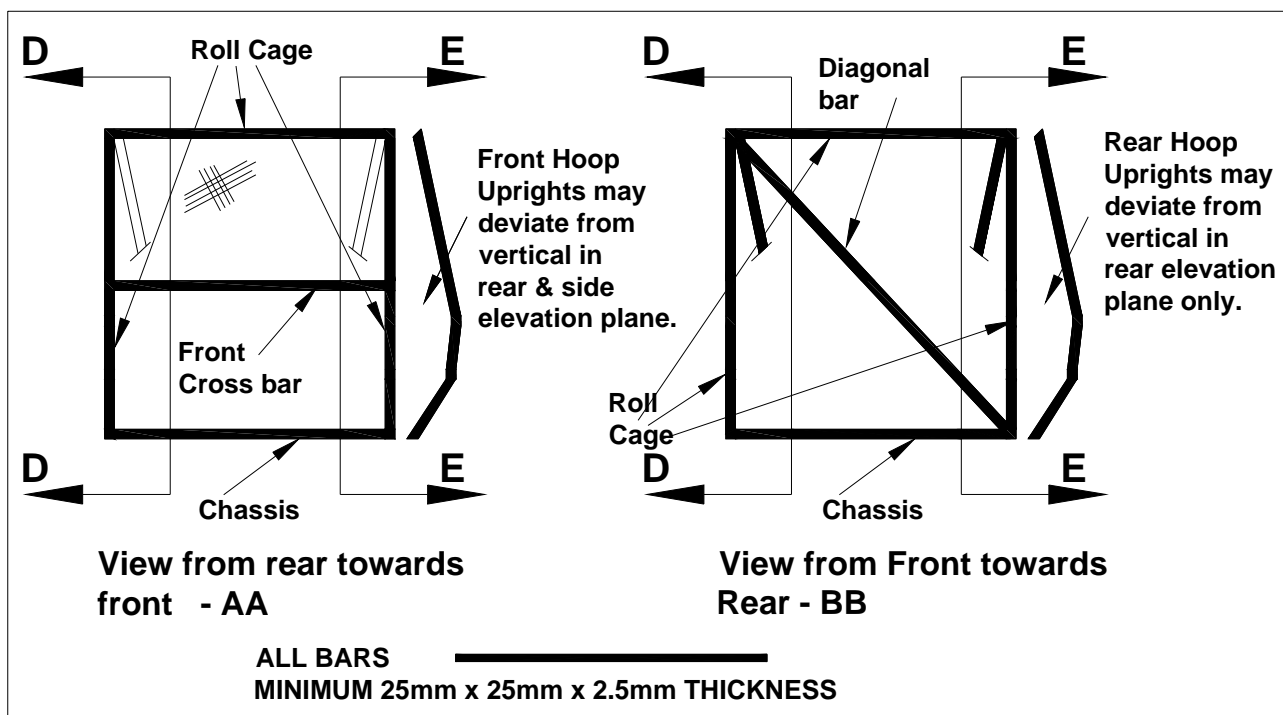

FIGURE 1d. Optional Bars.

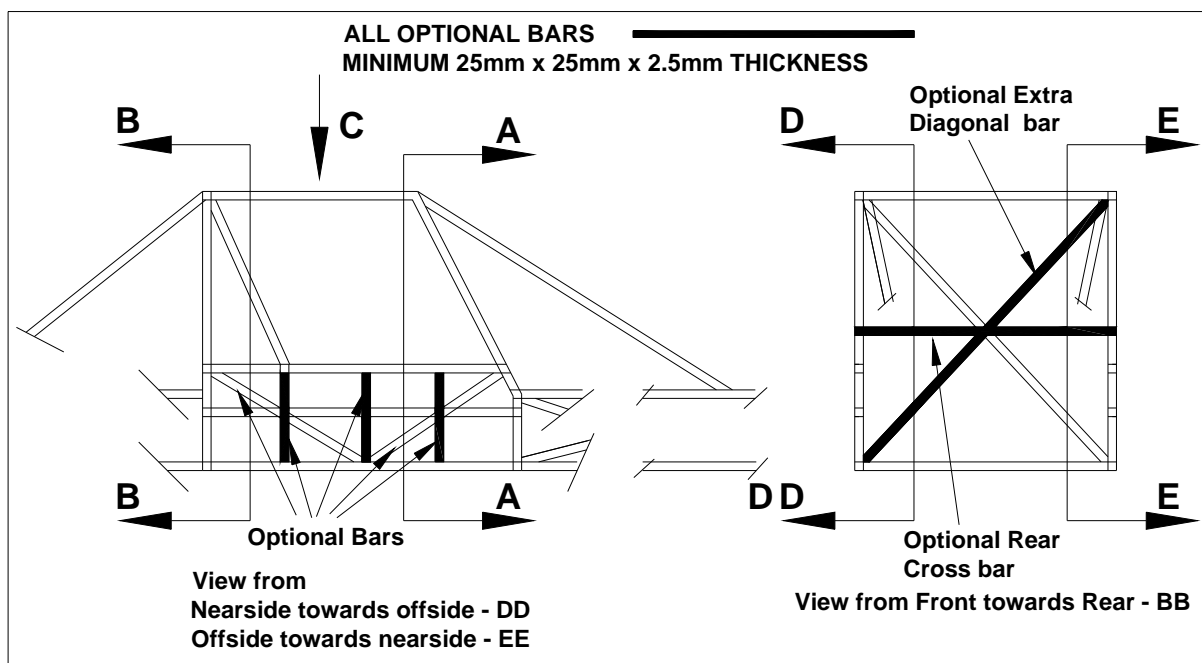

FIGURE 1e.
Optional Bars.

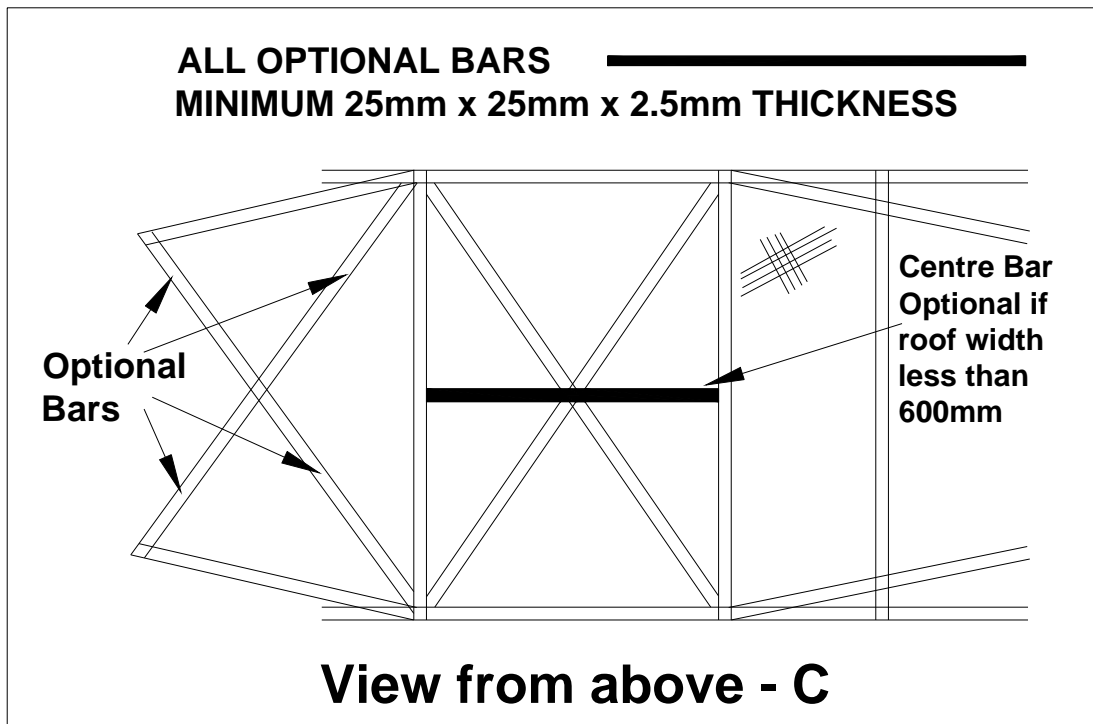
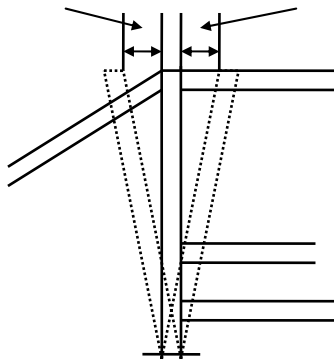

FIGURE 2.

ROLL CAGE REAR UPRIGHT:
MAXIMUM PERMITTED
DEVIATION FROM VERTICAL.
 - 50mm(2") + 50mm(2")



UPRIGHT BAR MUST BE STRAIGHT
WHEN VIEWED FROM THE SIDE.

GJf

GJf

FIGURE 3.

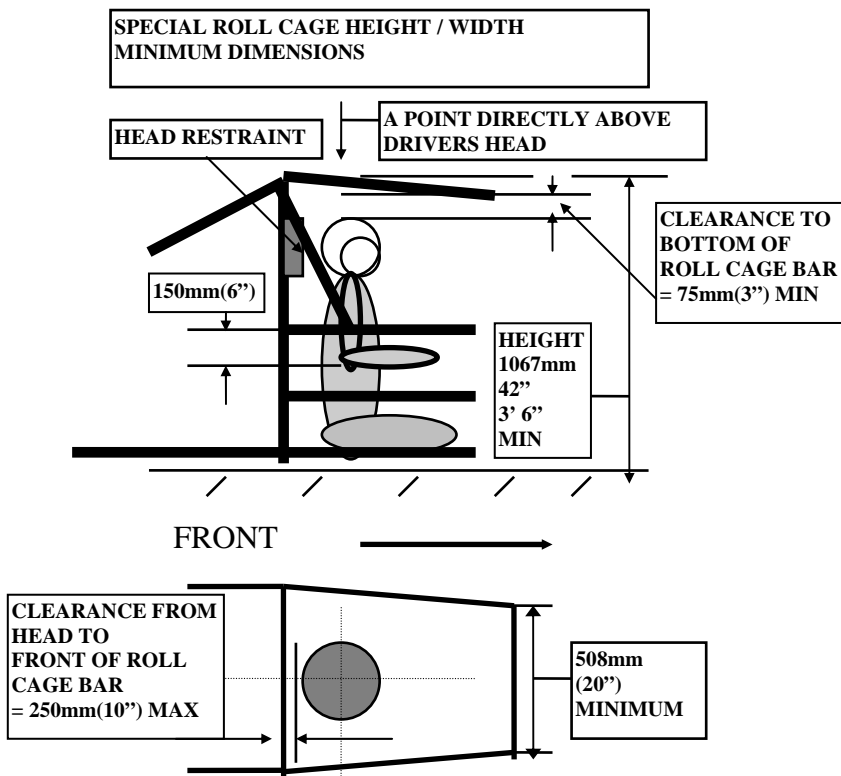

g/i

FIGURE 4

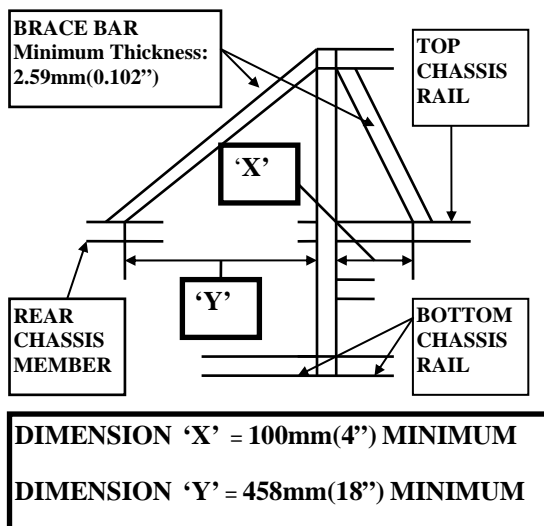

G/j

FIGURE 5 SIDE & CROSS BAR / UPRIGHT RELATIONSHIP.

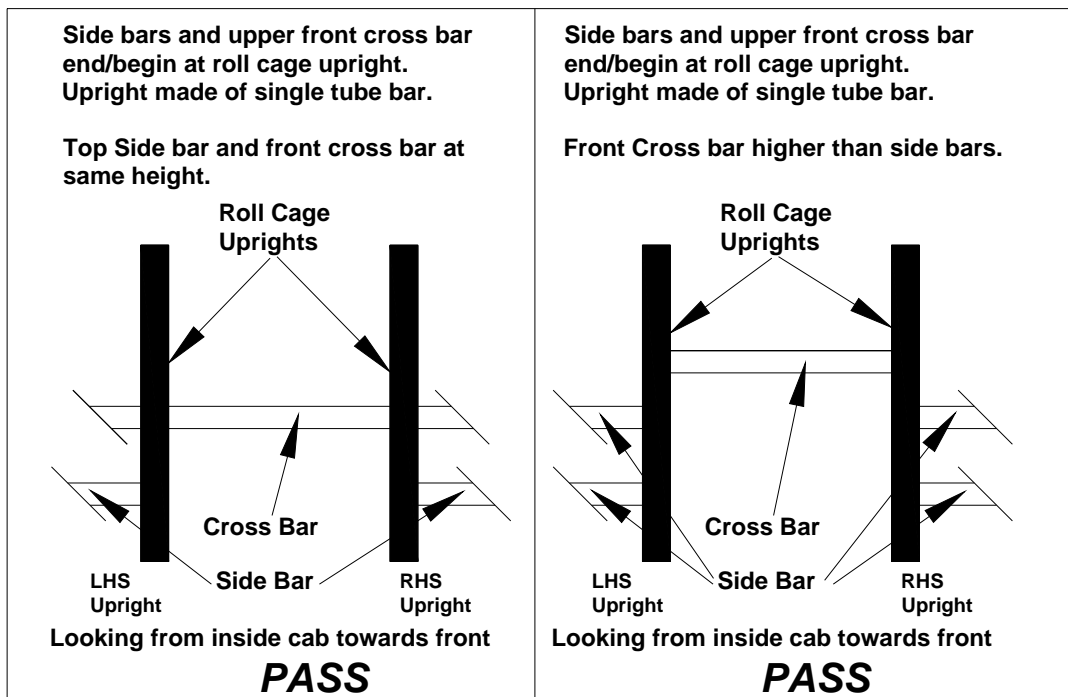
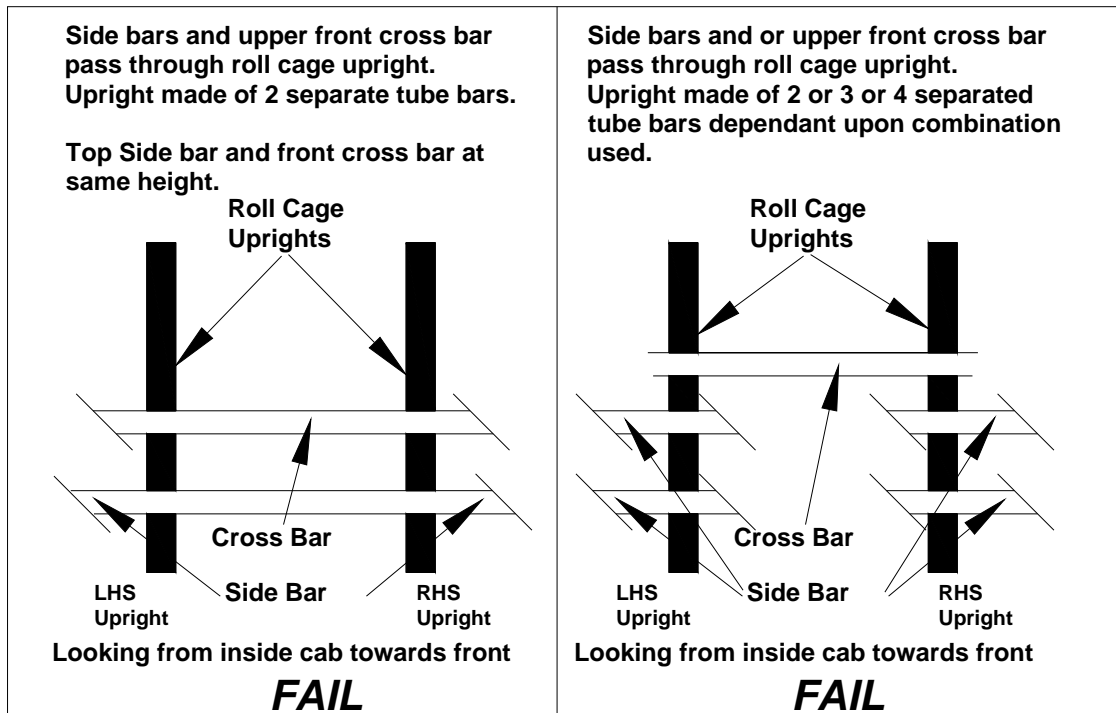
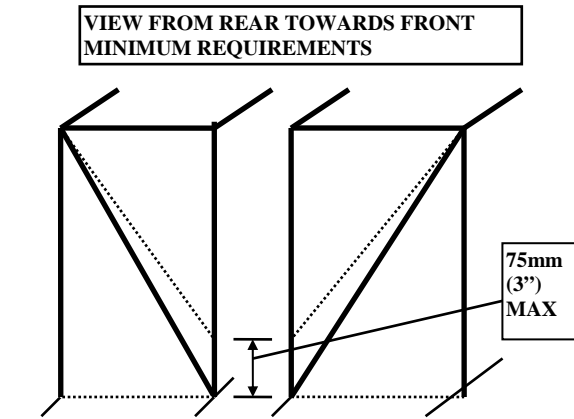

FIGURE 8 ROLL CAGE – Diagonal deviation.



EACH ROLL CAGE UPRIGHT MUST
BE CONNECTED TO BOTTOM
CHASSIS RAIL.

G/J

FIGURE 9 SIDE PROTECTION.

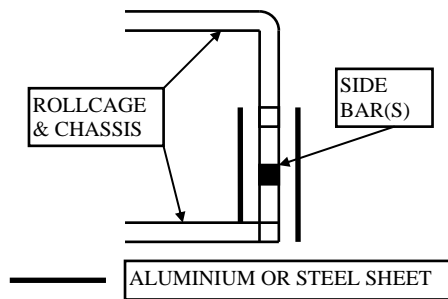

G/J

FIGURE 10 SIDE PROTECTION.

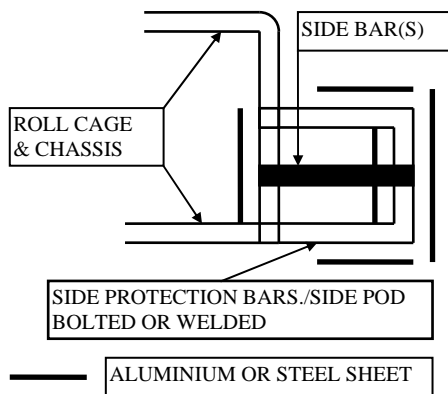

G/J

FIGURE 11 SIDE PROTECTION.

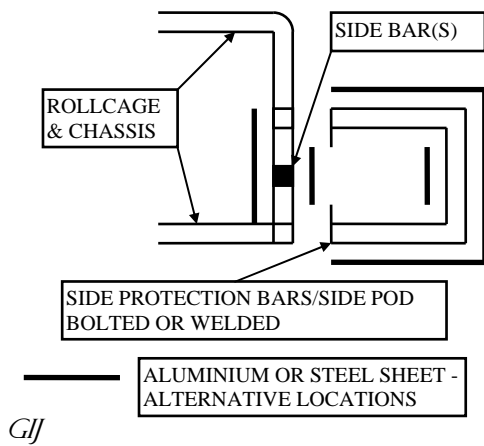

FIGURE 12 SIDE PROTECTION.

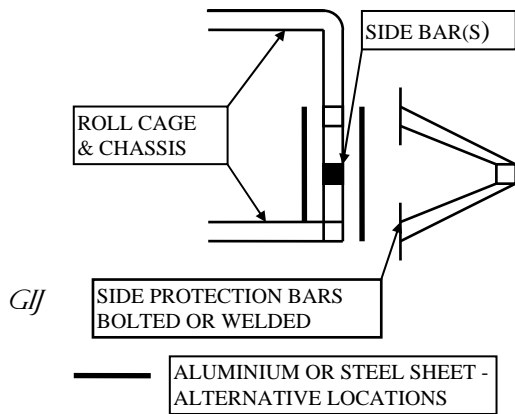

FIGURE 13 SIDE PROTECTION.

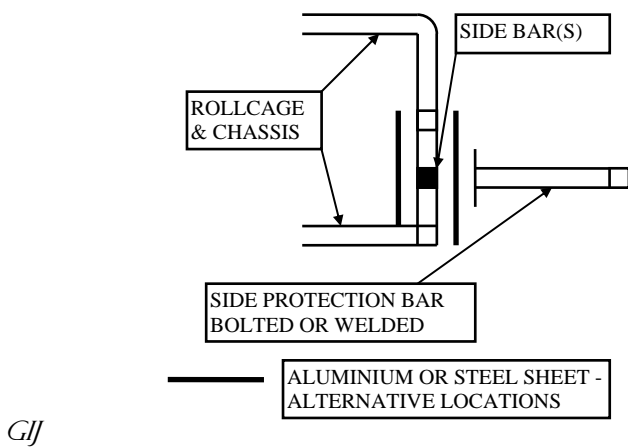
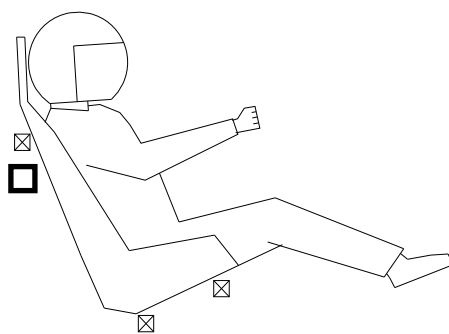

FIGURE 14 SEAT FIXING POINTS.



⊗ **FIXING POINTS**
As seat manufacturer's recommendations

Seat Support Bar □
Minimum Box Section = 25 mm x 25 mm x 2.5mm Wall Thickness
Minimum Circular Section = 25mm x 2.5mm Wall Thickness
Seat Fixing Bolts = 8mm HT or greater.

GJ/

FIGURE 15 VEHICLE IDENTIFICATION.

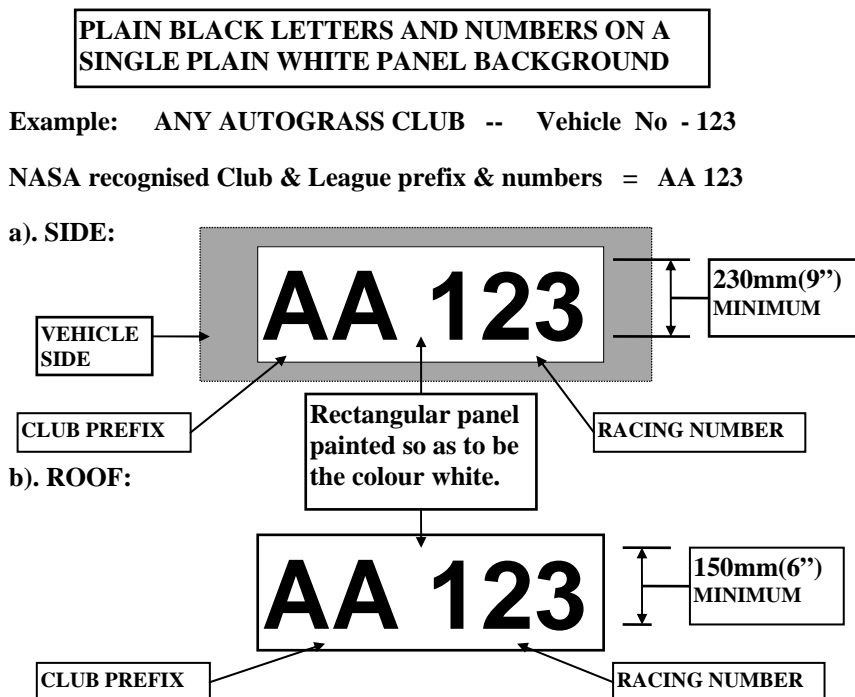

The Identification (Club letters & Racing number) must match that stated in the competitor's NASA Licence. i.e. if AA123 = AA123 Not 123AA or A123A. Identification must be located forward of Rear Roll Cage upright. All letters & Numbers must be clear, legible and upright. Clearance between outside edge of letter and or number to outside edge of white panel: Side: = 50mm. Roof: = 5mm.

gij

FIGURE 16 METAL ROOF NUMBER PANEL.

Identification panel must be located forward of Rear Roll Cage upright.

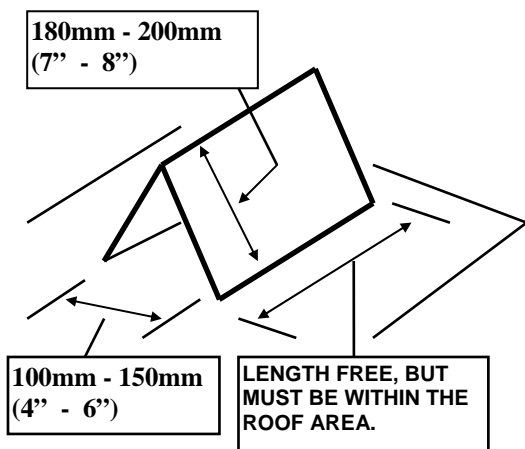

GJJ

FIGURE 17 LOCATION OF BATTERY CUT OFF SWITCH.

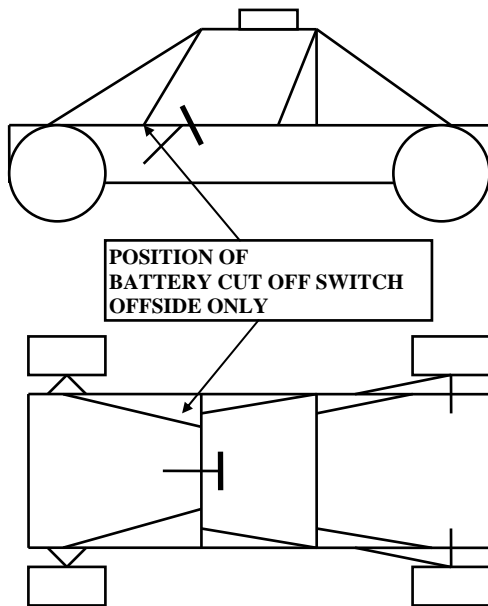

GJJ

FIGURE 18 RADIATOR & EXPANSION TANK LOCATION.

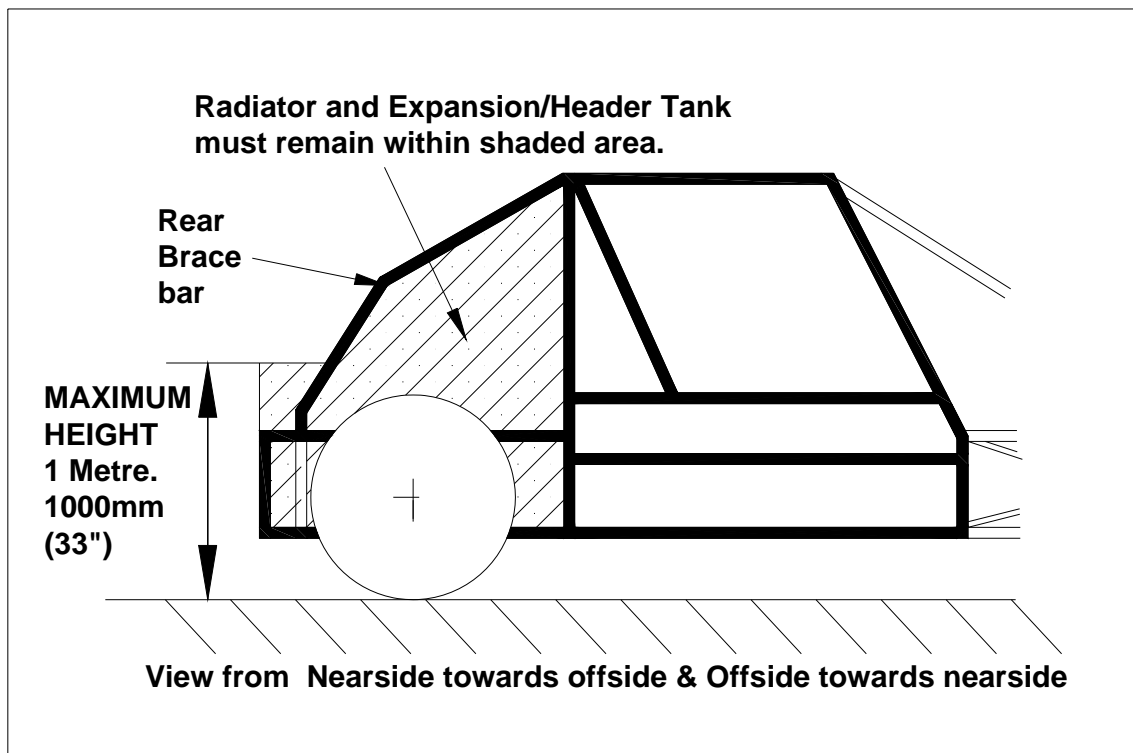

GJJ

FIGURE 19a SEAT BELT HARNESS TOP STRAP.

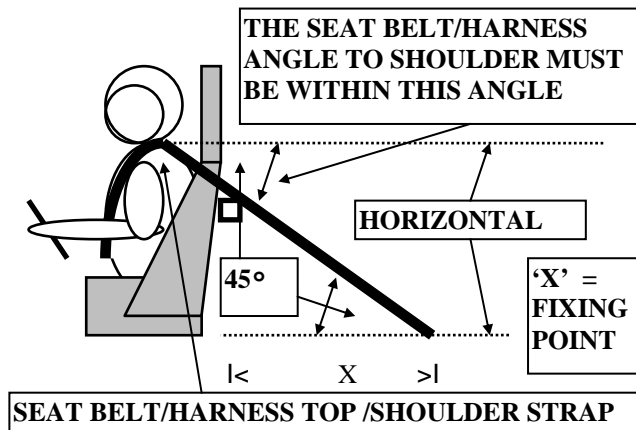

Seat Support Bar
GJJ

FIGURE 19b SEAT BELT HARNESS SUPPORT BAR.

FIG 10b
SAFETY HARNESS
SUPPORT BAR

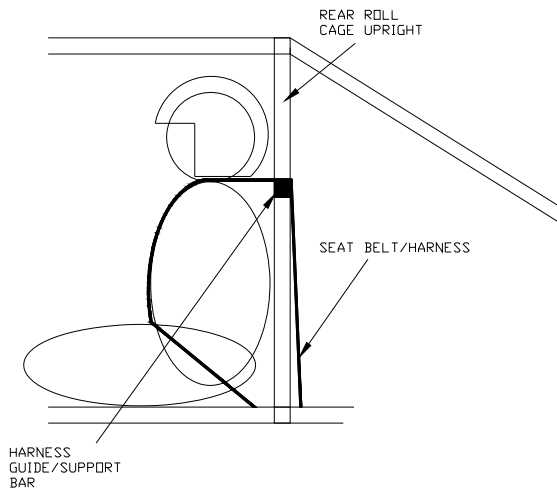

GJJ

FIGURE 19c . HARNESS STEEL EYE BOLT MOUNTING PLATE.
SEAT SUPPORT
ROLL BAR FIXINGS

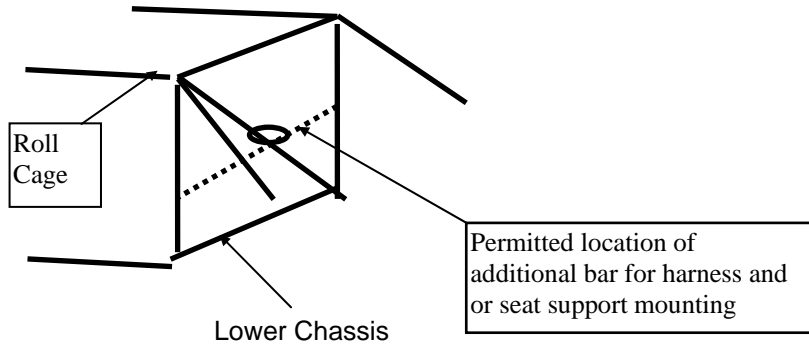

gij

FIGURE 20.

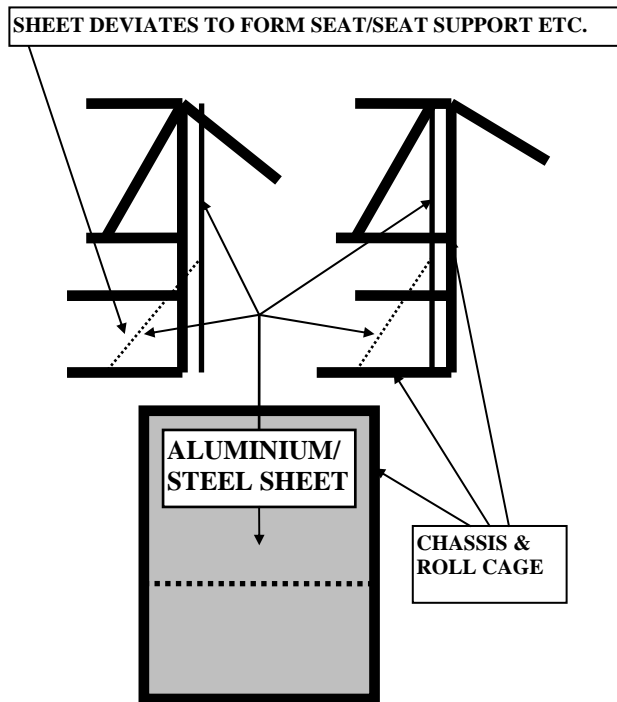

GJj

FIGURE 21 DRIVER'S COMPARTMENT.

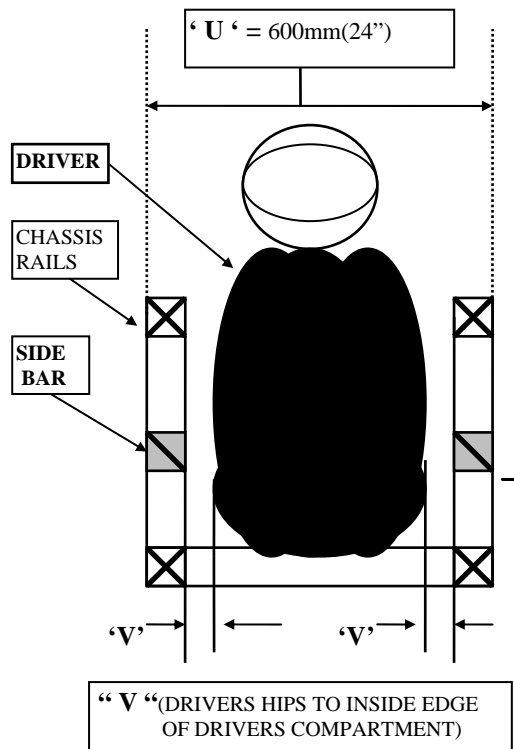

GJ

FIGURE 22 EXHAUST AREA.

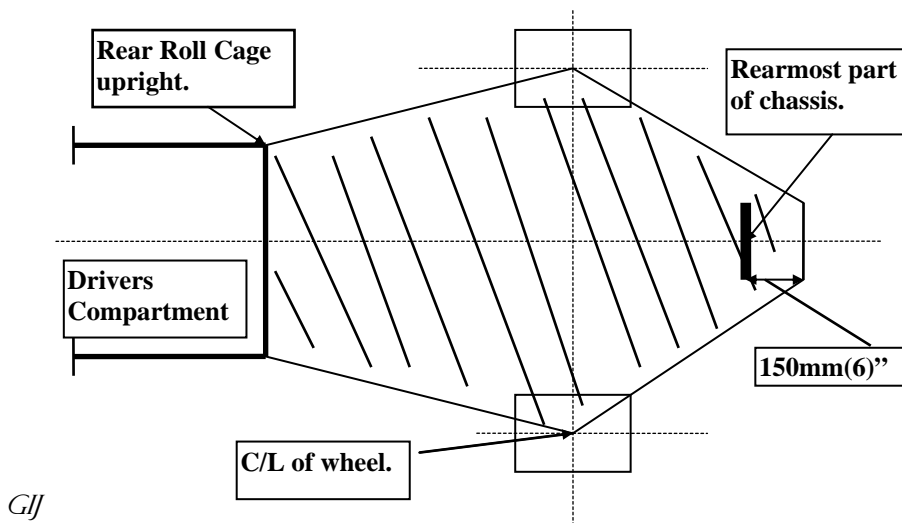

FIGURE 23 CHAIN GUARD.

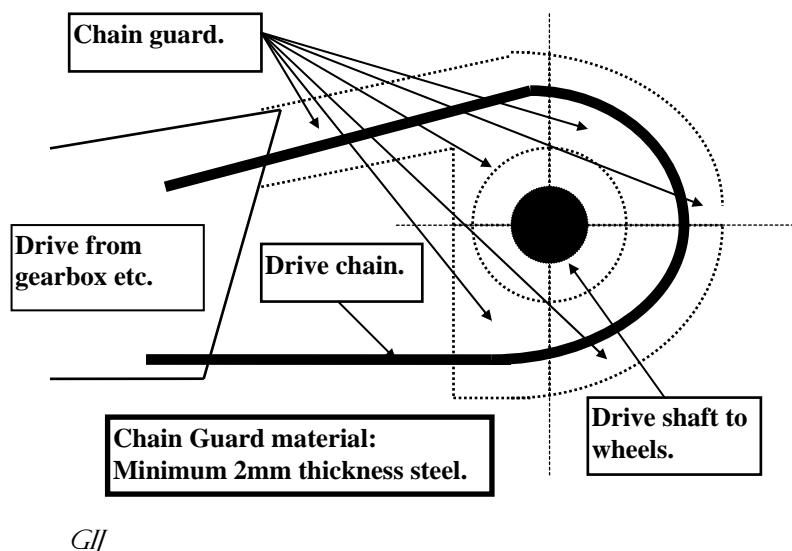

FIGURE 24a TWIN EXHAUST OUTLETS

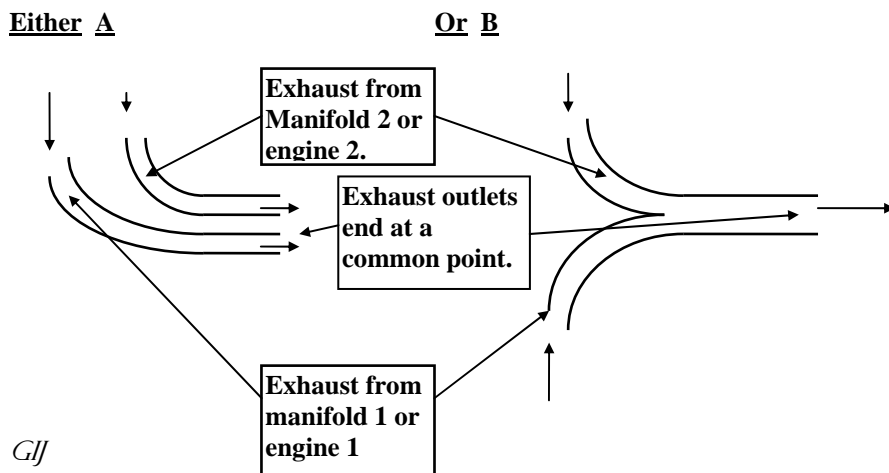

FIGURE 24b TWIN EXHAUST OUTLETS.

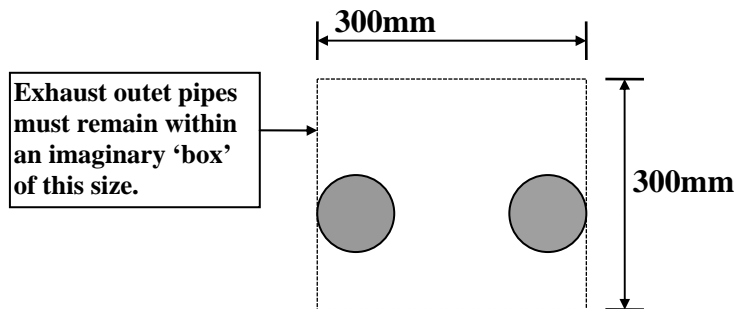

FIGURE 25 ENGINE SHIELD.

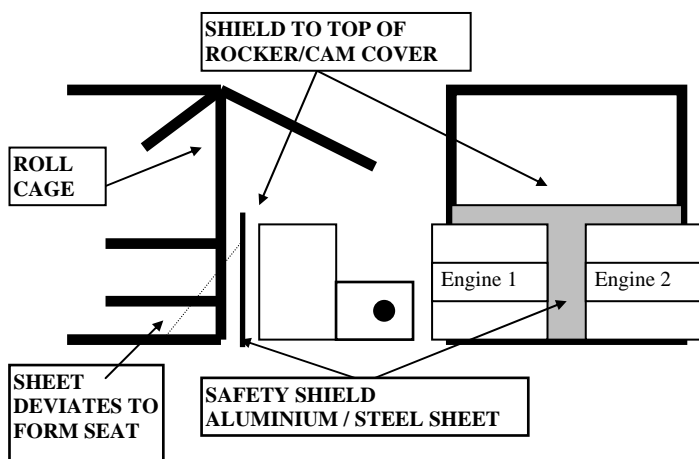
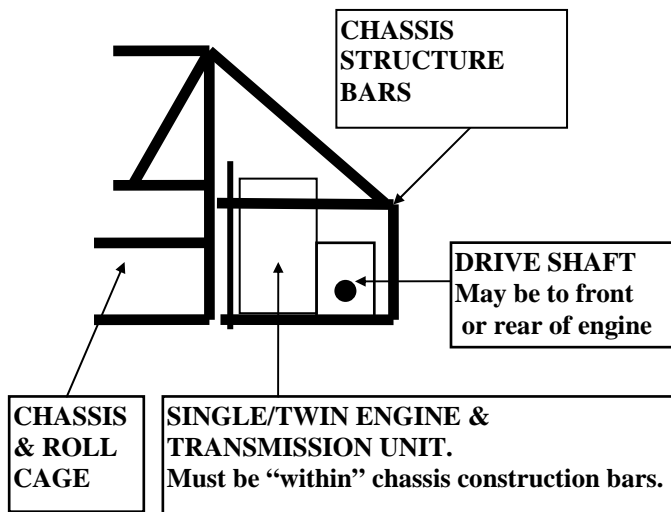

FIGURE 26a Rear Engine Requirements.

Rear



GJJ

FIGURE 26b Front Engine Requirements.

Note: As of January 2016 front engine vehicles prohibited unless registered with NASA and authorised prior to January 2016 and fitted with a "NASA Tag".

Front

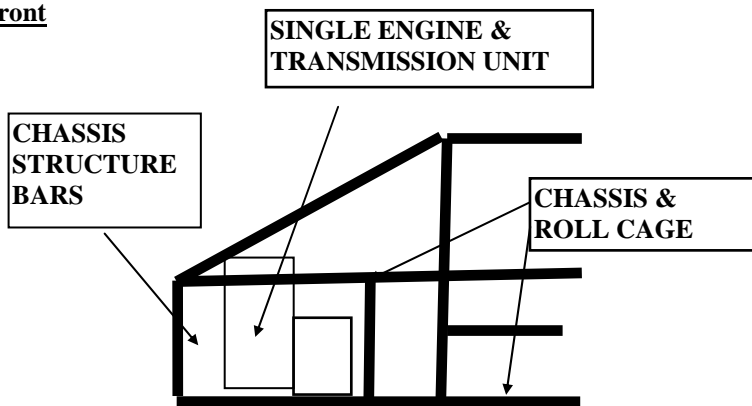

GJJ

FIGURE 27a. CAB & CHASSIS REQUIREMENTS.

Note: Figure is diagrammatic.

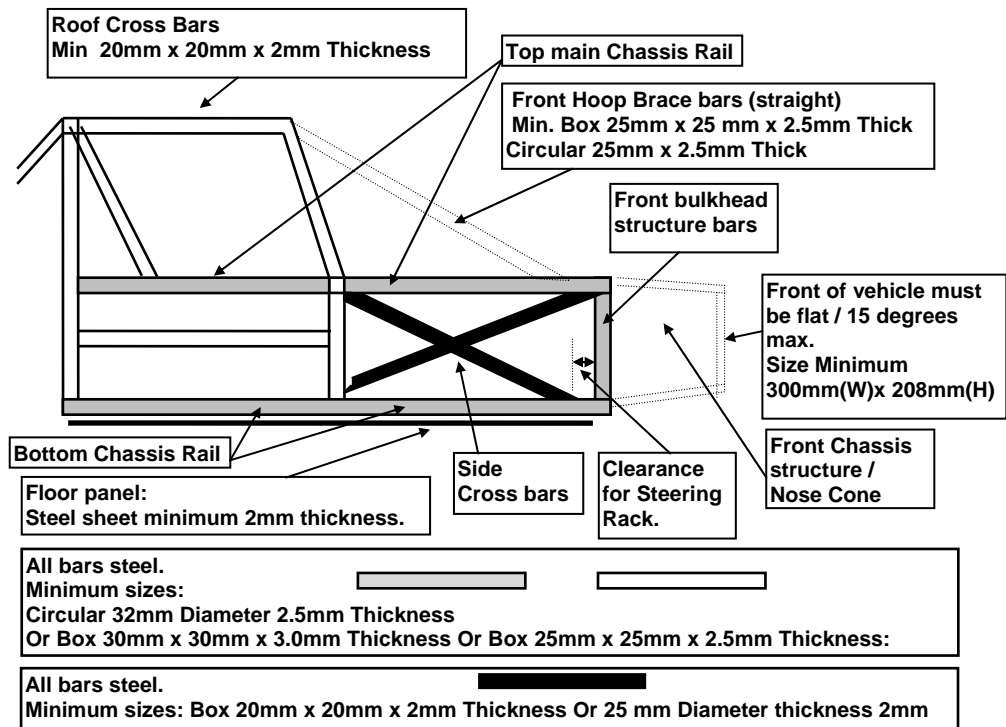

gii

FIGURE 27b. CAB & CHASSIS REQUIREMENTS.

Note: Figure is diagrammatic.

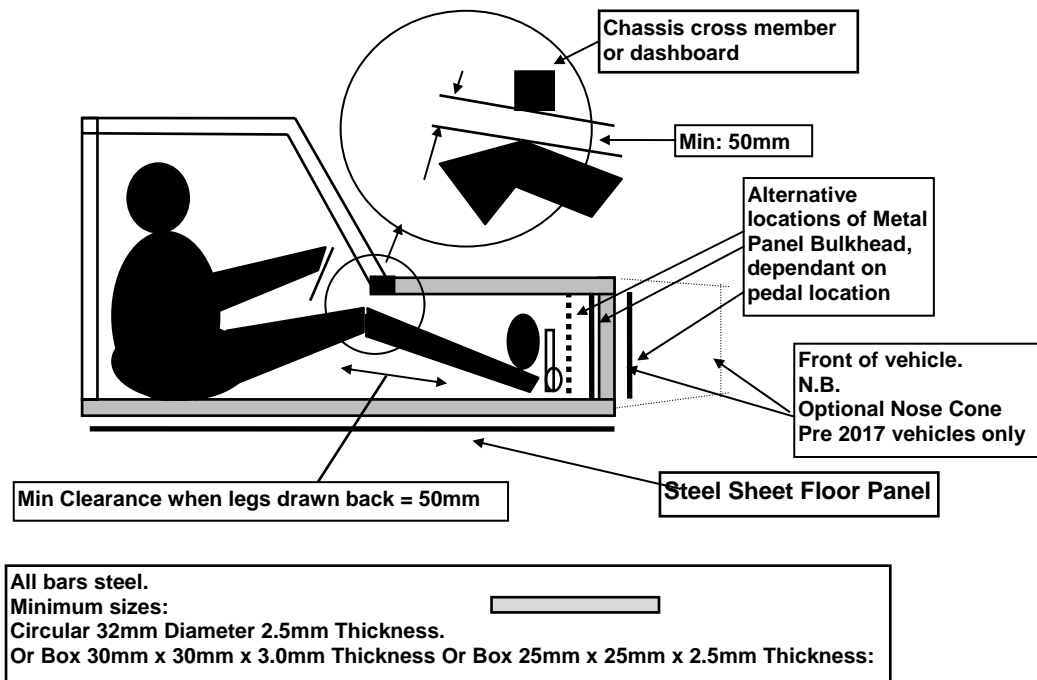

gij

FIGURE 27c FRONT BULKHEAD REQUIREMENTS

Note: Figure is diagrammatic.

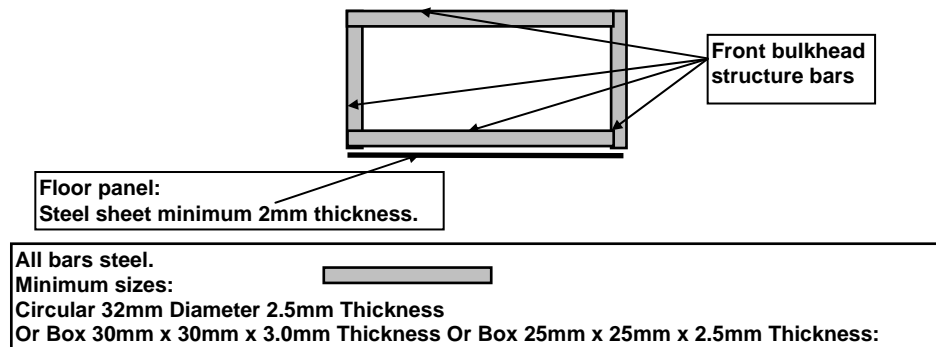

FIGURE 27d FLOOR PANEL REQUIREMENTS

Note: Figure is diagrammatic.

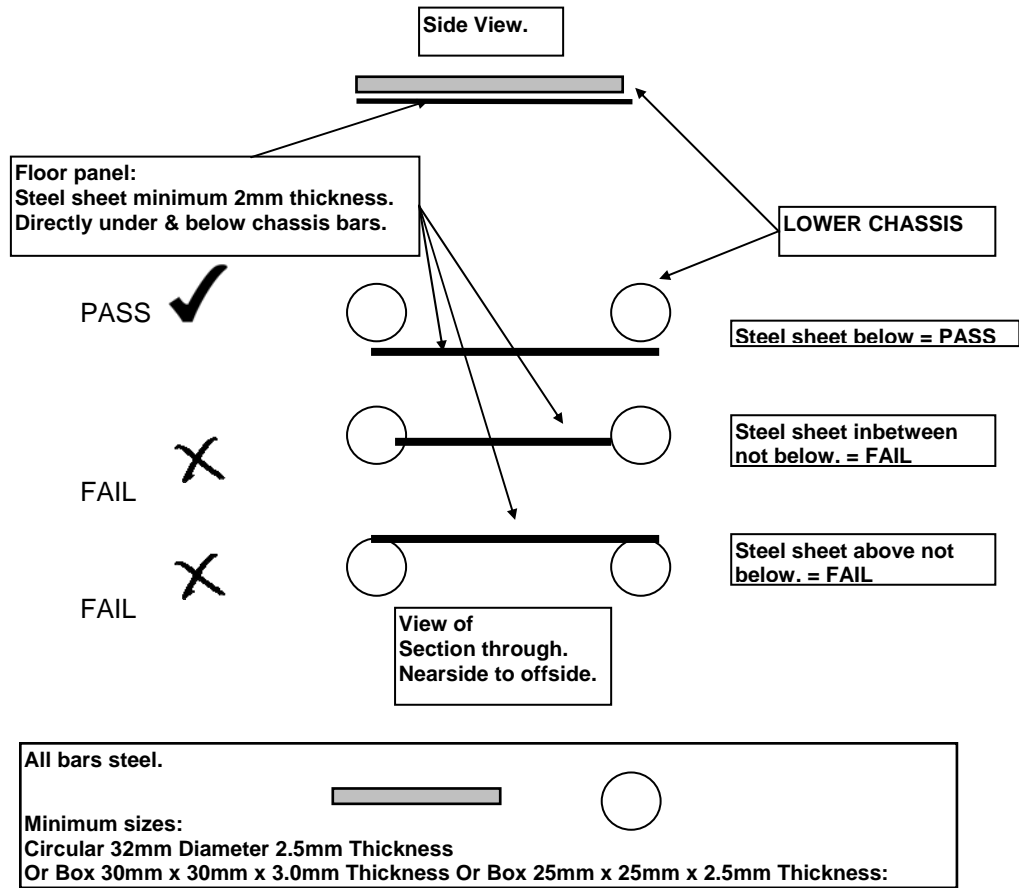
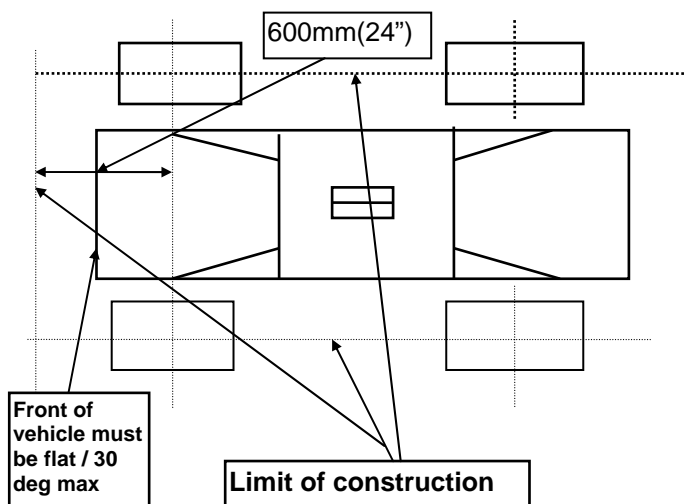

FIGURE 29 LIMITS OF CONSTRUCTION.



GJJ

FIGURE 30 SIDE PROTECTION BAR LOCATION.

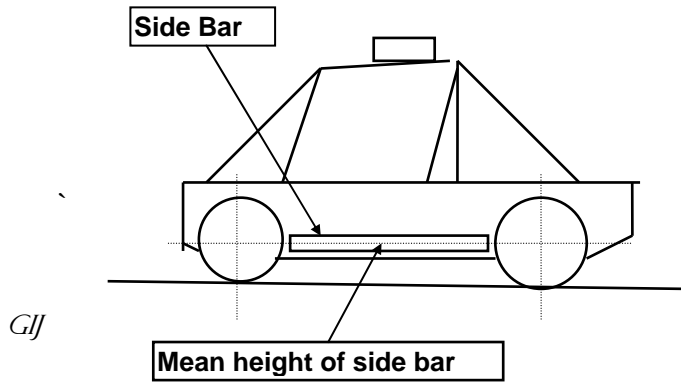

FIGURE 31a – ENGINE SEALING.

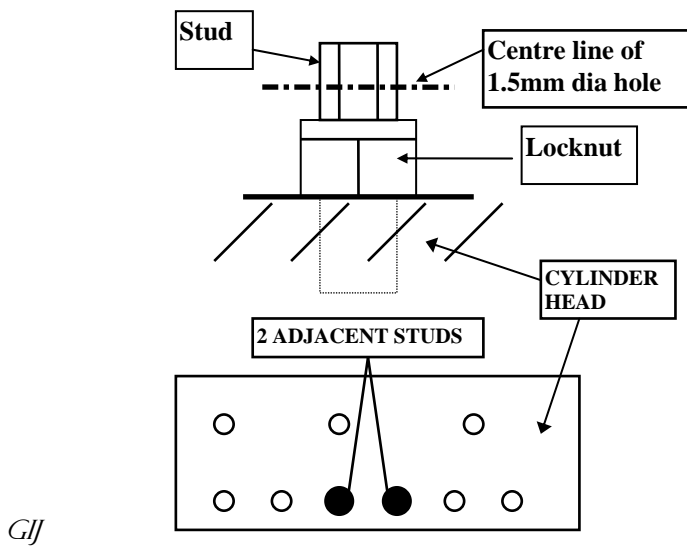
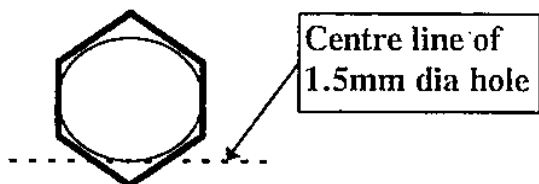
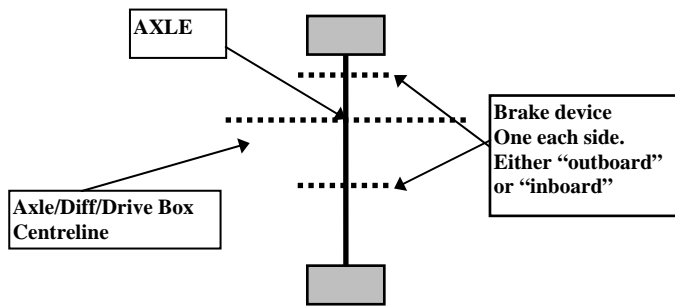

FIGURE 31b – ENGINE SEALING.



GJJ

FIGURE 32 – BRAKES.



Gj

FIGURE 33 SPECIAL FRONT/NOSE CONE – REQUIREMENTS.

SPECIAL FRONT	
<p>15°</p>	<p>Front panel and or chassis and or nose cone must present a straight and flat front. It must be not less than 300mm (12”) wide and 208mm (8”) high. It must be either vertical or within 15 degrees to the vertical.</p>
<p style="text-align: center;">PERMITTED = PASS ✓</p>	
<p style="text-align: center;">NOT PERMITTED = FAIL ✗</p>	

Gj

FIGURE 34 BALLAST REQUIREMENTS..

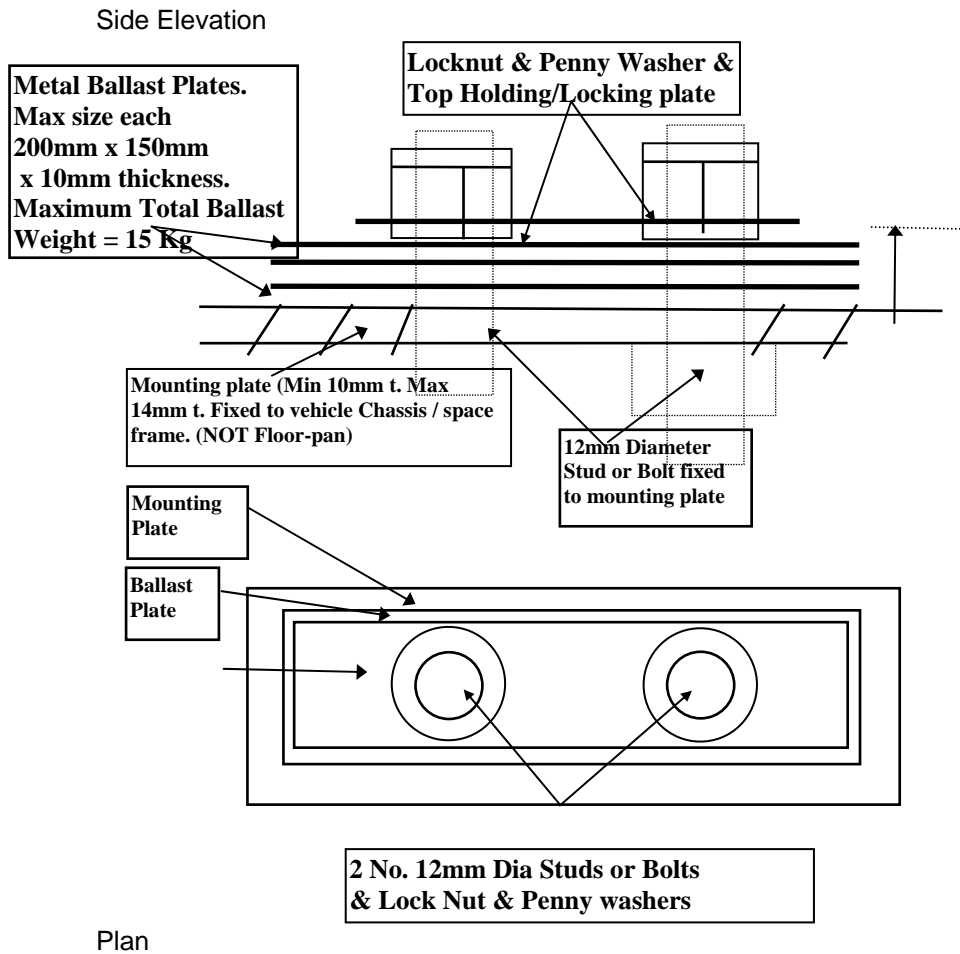

gii

FIGURE 35 DRIVERS COMPARTMENT APERTURE WEBBING/MESH REQUIREMENTS. – Both Nearside & Offside.

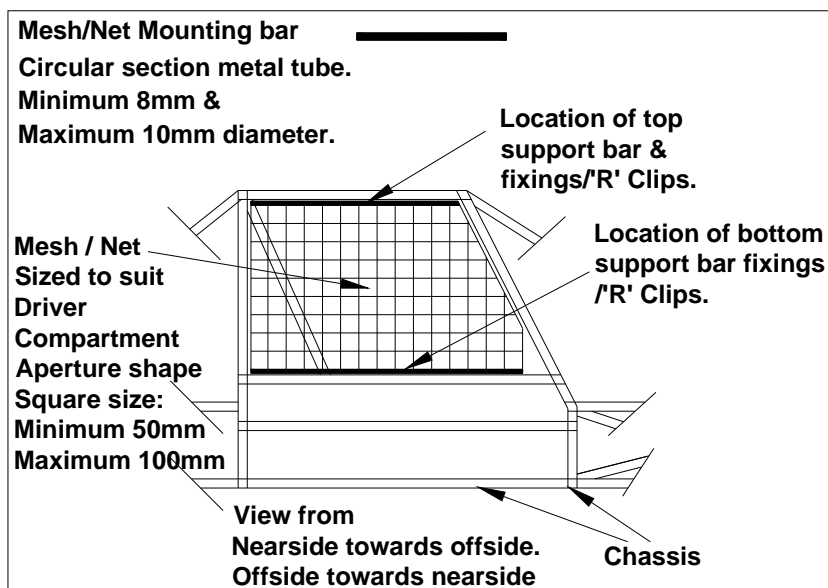

gii

SILENCING

The maximum noise permissible for all vehicles is 102 Db (A).

Sound level meter readings shall be taken at 0.5 of a metre from the exhaust outlet with the microphone of the Noise Meter at 45 degrees to the exhaust axis, and with the car engine running at the appropriate r.p.m. A list of engines/r.p.m's. is available from the scrutineers.

Noise Meter Standards (minimum requirements):

- Type 1 or 2 instrument.
- International Standard IEC 651
- British Standard BS 5969.
- Range 70-120dB(A)
- Time constants Fast/Slow.
- Maximum "Hold" recommended.

NB - Please see Members Book for more detailed information

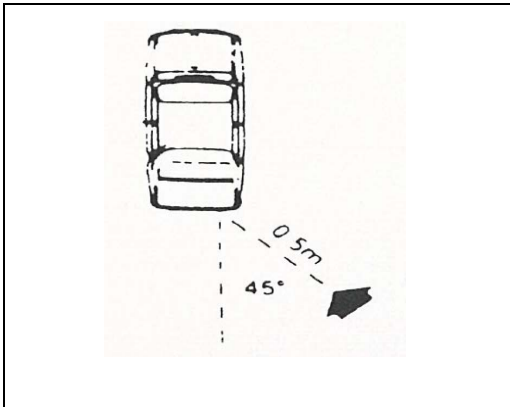

TABLE

British Standard Wire Gauges

Gauge	Diameter	(mm)
0	0.324	8.23
1	0.300	7.62
2	0.276	7.01
3	0.252	6.41
4	0.232	5.89
5	0.212	5.38
6	0.192	4.87
7	0.176	4.47
8	0.160	4.06
9	0.144	3.65
10	0.128	3.25
11	0.116	2.95
12	0.104	2.64
14	0.080	2.03
16	0.064	1.62
18	0.048	1.22
20	0.036	0.91
22	0.028	0.71

NASA NOISE TEST CHART

CLASS	ENGINE	TEST RPM
1	4 Cyl	4500
2	4 Cyl	4500
3	4 Cyl	5000
	V4 / V6 / V8	4500
	Chevy V8	3500
4	4 Cyl	5000
5	4 Cyl	5000
6	4 Cyl	5000
	V4 / V6 / V8	4500
7	4 Cyl	5000
	M'Bike	8000
	V4 / V6 / V8	4500
	Chevy V8	3500
	Twin M'Bike	8000
	M'Bike V8	8000
8	4 Cyl	5000
	M'Bike	8000
9	4 Cyl	5000
	V4 / V6 / V8	4500
10	4 Cyl	5000
	V4 / V6 / V8	4500
	Chevy V8	3500
	Twin M'Bike	8000
	M'Bike V8	8000

The construction rules in this book are intended for use by Autograss cars taking part in Autograss events as defined by the NATIONAL AUTOGRASS SPORT ASSOCIATION on a natural surface and are not necessarily considered safe for other forms of motor sport.

Drivers are advised that if they intend using their cars at events, other than events as defined by the NATIONAL AUTOGRASS SPORT ASSOCIATION They should ensure that their cars comply with the organiser's construction rules.

® AUTOGRASS IS A REGISTERED TRADEMARK OF THE NATIONAL AUTOGRASS SPORT ASSOCIATION

© NATIONAL AUTOGRASS SPORT ASSOCIATION LTD 2020